

SERVICE & OPERATING MANUAL

Original Instructions

MARATHON®

A WARREN RUPP, INC. BRAND

Model M20 Metallic Design Level 1

Table of Contents

Engineering Data and Temperature Limitations	1
Explanation of Pump Nomenclature	2
Performance Curve	3
Dimensions	4
Metric Dimensions	5
Principle of Pump Operation.....	6
Installation and Start-Up	6
Air Supply	6
Air Valve Lubrication.....	6
Air Line Moisture.....	6
Air Inlet and Priming	6
Between Uses	6
Installation Guide.....	7
Troubleshooting	8
Warranty	8
Recycling	9
Important Safety Information	9
Material Codes	10
Composite Repair Parts Drawing	12
Available Service and Conversion Kits.....	12
Composite Repair Parts List	13
Air Valve Drawing, Parts List, Service Instructions (Aluminum Centers Only)	14
Air Valve Drawing, Parts List, Service Instructions.....	15
Air Valve w/Stroke Indicator Drawing, Parts List, Service Instructions	16
Air Valve Drawing, Parts List, Service Instructions (Cast Iron Centers Only).....	17

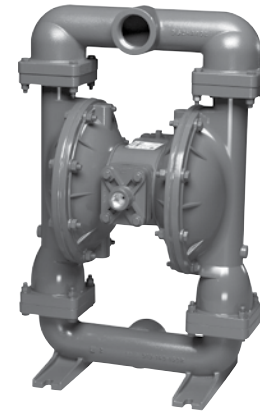

See pages 2, 30 and 31
for ATEX ratings.



Solenoid Shifted Air Valve Drawing	18
Solenoid Shifted Air Valve Parts List	19
Solenoid Shifted Air Valve Option.....	20
Diaphragm Service Drawing, with Overlay	20
Diaphragm Service Drawing, Non-Overlay.....	20
Diaphragm Service Drawing, with One-Piece Bonded	20
Diaphragm Servicing	21
Overlay Diaphragm Servicing	21
Pilot Valve Servicing, Assembly Drawing & Parts List	22
Actuator Plunger Servicing.....	23
Check Valve Servicing.....	24
Check Valve Drawing	24
Optional Muffler Configurations	25
Optional Muffler Configuration Drawing.....	25
Pumping Hazardous Liquids.....	26
Converting Pump for Piping Exhaust Air	26
Converted Exhaust Illustration.....	26
Pulse Output Kit Drawing	27
Pulse Output Kit Options	27
Grounding the Pump	28
CE Declaration of Conformity Machinery	29
CE Declaration of Conformity ATEX	30
Explanation of ATEX Certifications	31

**WARREN
RUPP®**

Quality System
ISO9001 Certified

Environmental
Management System
ISO14001 Certified

IDEX
FLUID & METERING

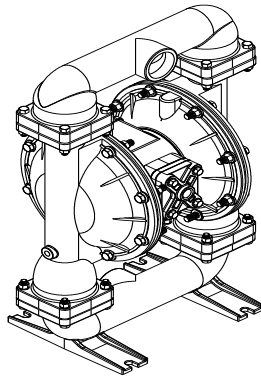

Air Inlet Side View

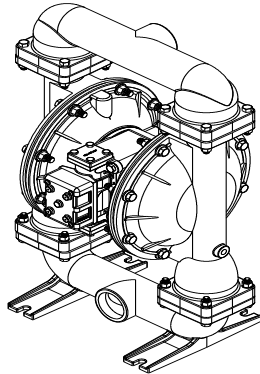

Air Exhaust Side View



See pages 2, 30 and 31
for ATEX ratings.

MARATHON®
A WARREN RUPP, INC. BRAND

**M20 Metallic
Design Level 1
Ball Valve**

**Air-Operated
Double Diaphragm Pump**

ENGINEERING, PERFORMANCE
& CONSTRUCTION DATA

INTAKE/DISCHARGE PIPE SIZE 2" NPT (internal) 2" BSP Tapered (internal)	CAPACITY 0 to 150 gallons per minute (0 to 567 liters per minute)	AIR VALVE No-lube, no-stall design	SOLIDS-HANDLING Up to .25 in. (6mm)	HEADS UP TO 125 psi or 289 ft. of water (8.6 Kg/cm ² or 86 meters)	DISPLACEMENT/STROKE .42 Gallon / 1.59 liter
<p>⚠ CAUTION! Operating temperature limitations are as follows:</p>					
<p>Materials</p>				<p>Operating Temperatures</p>	
				<p>Maximum</p>	<p>Minimum</p>
<p>Nitrile General purpose, oil-resistant. Shows good solvent, oil, water and hydraulic fluid resistance. Should not be used with highly polar solvents like acetone and MEK, ozone, chlorinated hydrocarbons and nitro hydrocarbons.</p>				<p>190°F 88°C</p>	<p>-10°F -23°C</p>
<p>EPDM Shows very good water and chemical resistance. Has poor resistance to oil and solvents, but is fair in ketones and alcohols.</p>				<p>280°F 138°C</p>	<p>-40°F -40°C</p>
<p>NEOPRENE All purpose. Resistant to vegetable oils. Generally not affected by moderate chemicals, fats, greases and many oils and solvents. Generally attacked by strong oxidizing acids, ketones, esters, nitro hydrocarbons and chlorinated aromatic hydrocarbons.</p>				<p>200°F 93°C</p>	<p>-10°F -23°C</p>
<p>PTFE Chemically inert, virtually impervious. Very few chemicals are known to react chemically with PTFE: molten alkali metals, turbulent liquid or gaseous fluorine and a few fluoro-chemicals such as chlorine trifluoride or oxygen difluoride which readily liberate free fluorine at elevated temperatures.</p>				<p>220°F 104°C</p>	<p>-35°F -37°C</p>
<p>FKM (Fluorocarbon) shows good resistance to a wide range of oils and solvents; especially all aliphatic, aromatic and halogenated hydrocarbons, acids, animal and vegetable oils. Hot water or hot aqueous solutions (over 70°F) will attack FKM.</p>				<p>350°F 177°C</p>	<p>-40°F -40°C</p>
<p>Santoprene® Injection molded thermoplastic elastomer with no fabric layer. Long mechanical flex life. Excellent abrasion resistance.</p>				<p>275°F 135°C</p>	<p>-40°F -40°C</p>
<p>Polypropylene A thermoplastic polymer. Moderate tensile and flex strength. Resists strong acids and alkalies. Attacked by chlorine, fuming nitric acid and other strong oxidizing agents.</p>				<p>180°F 82°C</p>	<p>32°F 0°C</p>
<p>UHMW PE A thermoplastic polymer that is highly resistant to a broad range of chemicals. Exhibits outstanding abrasion and impact resistance, along with environmental stress-cracking resistance.</p>				<p>180°F 82°C</p>	<p>-35°F -37°C</p>
<p>For specific applications, always consult "Chemical Resistance Chart" Technical Bulletin</p>				<p>Maximum and Minimum Temperatures are the limits for which these materials can be operated. Temperatures coupled with pressure affect the longevity of diaphragm pump components. Maximum life should not be expected at the extreme limits of the temperature ranges.</p>	

Explanation of Pump Nomenclature, M20 Metallic • Design Level 1 • Ball Valve

Model	Pump Brand	Pump Size	Check Valve Type	Design Level	Wetted Material	Diaphragm/Check Valve Materials	Check Valve Seat	Non-Wetted Material Options	Porting Options	Pump Style	Pump Options	Kit Options	Shipping Weight lbs. (kg)
M20B1ABBANS000.	M	20	B	1	A	B	B	A	N	S	0	00.	69 (31)
M20B1AEEANS000.	M	20	B	1	A	E	E	A	N	S	0	00.	69 (31)
M20B1AGTANS000.	M	20	B	1	A	G	T	A	N	S	0	00.	69 (31)
M20B1ANNANS000.	M	20	B	1	A	N	N	A	N	S	0	00.	69 (31)
M20B1A1EANS000.	M	20	B	1	A	1	E	A	N	S	0	00.	69 (31)
M20B1IBBANS000.	M	20	B	1	I	B	B	A	N	S	0	00.	129 (59)
M20B1IEEANS000.	M	20	B	1	I	E	E	A	N	S	0	00.	129 (59)
M20B1ICTANS000.	M	20	B	1	I	C	T	A	N	S	0	00.	129 (59)
M20B1SBBANS000.	M	20	B	1	S	B	B	A	N	S	0	00.	114 (52)
M20B1SGTANS000.	M	20	B	1	S	G	T	A	N	S	0	00.	114 (52)
M20B1S1EANS000.	M	20	B	1	S	1	E	A	N	S	0	00.	114 (52)

Note: Models listed in the table are for reference only. See nomenclature below for other models.

Pump Brand
M= MARATHON®

Pump Size
20= 2"

Check Valve Type
B= Ball
W= Weighted

Design Level
1= Design Level

Wetted Material
A= Aluminum
I= Cast Iron
S= Stainless Steel
H= Alloy C

Diaphragm Check Valve Materials

- 1= Santoprene/Santoprene
- 2= PTFE-Santoprene/PTFE
- B= Nitrile/Nitrile
- C= FKM/PTFE
- E= EPDM/EPDM
- I= EPDM/Santoprene
- G= PTFE-Neoprene/PTFE
- N= Neoprene/Neoprene
- Z= One-Piece Bonded/PTFE

Check Valve Seat

- A= Aluminum
- B= Nitrile
- C= Carbon Steel
- E= EPDM

Check Valve Seat Cont.

- N= Neoprene
- S= Stainless Steel
- T= PTFE
- V= FKM
- W=UHMW Polyethylene

Non-Wetted Material Options

- A= Painted Aluminum
- I= Cast Iron
- J= Painted Aluminum w/PTFE Coated Hardware
- S= Stainless Steel with Stainless Steel Hardware
- Y= Painted Aluminum with Stainless Steel Hardware
- Z= Cast Iron with Stainless Steel Hardware

Porting Options

- N= NPT Threads
- B= BSP (Tapered) Threads
- R= Raised Face 150# Threaded ANSI Flange

Pump Style

- S= Standard

Pump Options

- 0= None
- 1= Sound Dampening Muffler
- 2= Mesh Muffler
- 3= High temperature Air Valve w/Integral Muffler
- 4= High temperature Air Valve w/Sound Dampening Muffler
- 5= High temperature Air Valve w/Mesh Muffler
- 6= Metal Muffler
- 7= Metal Muffler w/Grounding Cable

Kit Options

- ▲ 00.= None
- P0.= 10-30VDC Pulse Output Kit
- ◇ P1.= Intrinsically-Safe 5-30VDC, 110/120VAC 220/240 VAC Pulse Output Kit
- P2.= 110/120 or 220/240VAC Pulse Output Kit
- E0.= Solenoid Kit with 24VDC Coil
- ▲ E1.= Solenoid Kit with 24VDC Explosion-Proof Coil
- E2.= Solenoid Kit with 24VAC/12VDC Coil
- ▲ E3.= Solenoid Kit with 12VDC Explosion-Proof Coil
- E4.= Solenoid Kit with 110VAC Coil
- ▲ E5.= Solenoid Kit with 110VAC Explosion-Proof Coil
- E6.= Solenoid Kit with 220VAC Coil

Kit Options continued

- ▲ E7.= Solenoid Kit with 220VAC Explosion-Proof Coil
- ▲ E8.= Solenoid Kit with 110VAC, 50 Hz Explosion-Proof Coil
- ▲ E9.= Solenoid Kit with 230VAC, 50 Hz Explosion-Proof Coil
- SP.= Stroke Indicator Pins
- ◆ A1.= Solenoid Kit with 12 VDC ATEX Compliant Coil
- ◆ A2.= Solenoid Kit with 24 VDC ATEX Compliant Coil
- ◆ A3.= Solenoid Kit with 110/120 VAC 50/60 Hz ATEX Compliant Coil
- ◆ A4.= Solenoid Kit with 220/240 VAC 50/60 Hz ATEX Compliant Coil

(1)  II 1G c T5
II 3/1 G c T5
II 1D c T100°C
! I M1 c
I M2 c

Models equipped with Wetted Options I, S or H, Non-Wetted Options I, S or Z, Pump Options 6 or 7, and Kit Option 0.
Note: See page 31 for ATEX Explanation of EC-Type Certificate



(2)  II 2G Ex ia c IIC T5
◇ II 3/2 G Ex ia c IIC T5
II 2D Ex c ia 20 IP67 T100°C

Note: Pumps ordered with the options listed in (1) to the left are ATEX compliant when ordered with kit option P1.

(3*)  II 2G EEx m c II T5
II 3/2 2G EEx m c II T5
◆ II 2D c IP65 T100°C

Note: Pumps ordered with the options listed in (1) to the left are ATEX compliant when ordered with kit option A1, A2, A3, or A4. Compressed Air Temperature Range: Maximum Ambient Temperature to plus 50°C.

*Note: See page 18 for Special Conditions For Safe Use.

(4)  IEC EEx m T4 
APPROVED
▲ Note: Pump models equipped with these explosion-proof solenoid kit options E1, E3, E5, E7, E8 or E9, are certified and approved by the above agencies. They are NOT ATEX compliant.

Performance Curve, M20 Metallic Design Level 1

Performance based on the following: elastomer fitted pump, flooded suction, water at ambient conditions.
 The use of other materials and varying hydraulic conditions may result in deviations in excess of 5%.

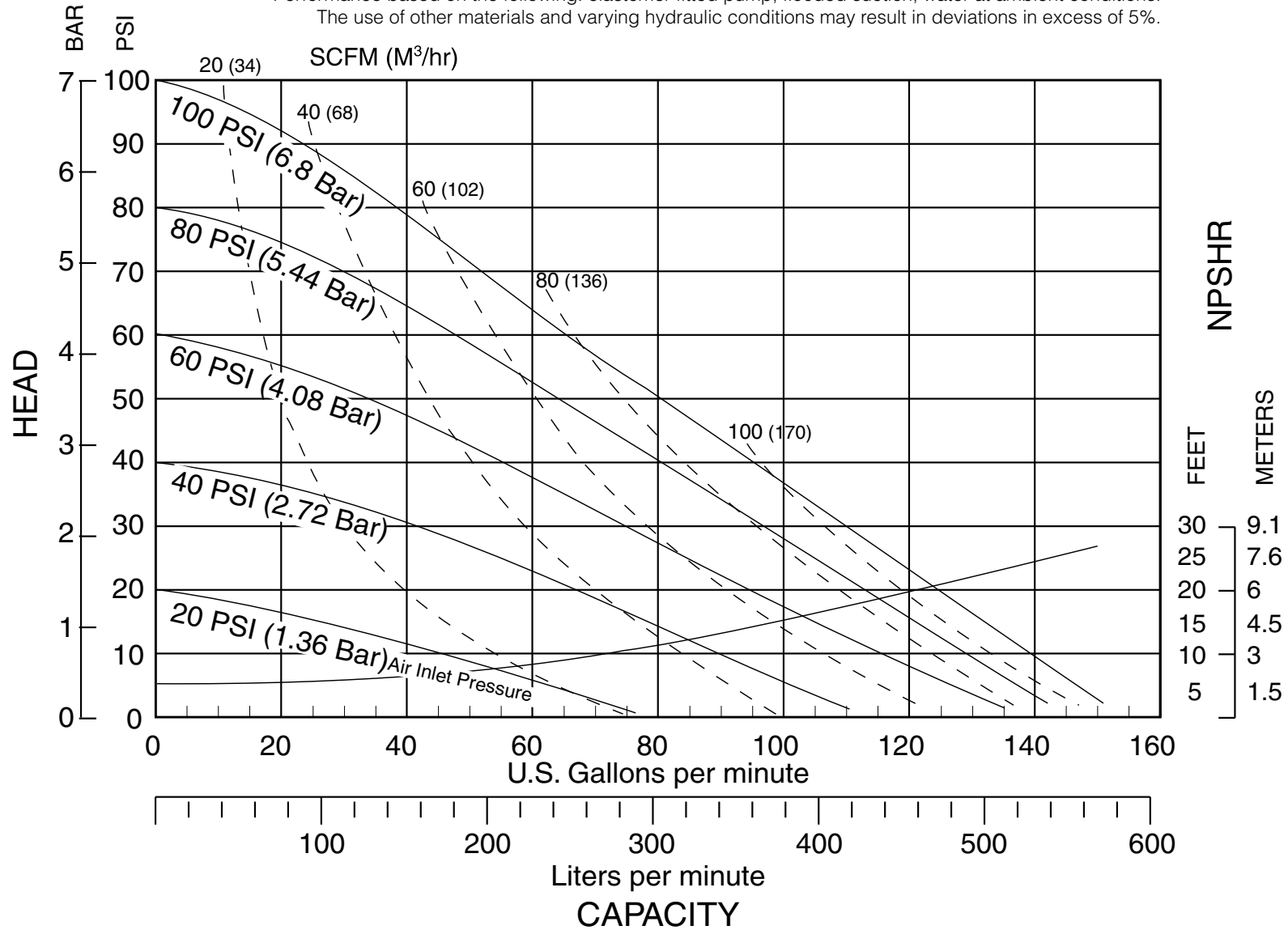

Dimensions: M20 Metallic

Dimensions in Inches
Dimensional Tolerance: $\pm 1/8$ "

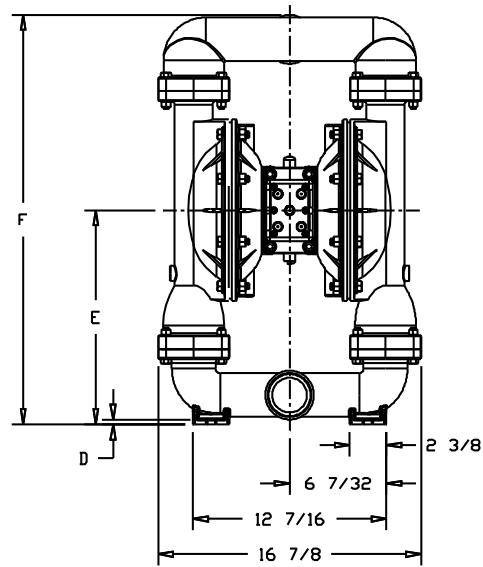

FRONT VIEW

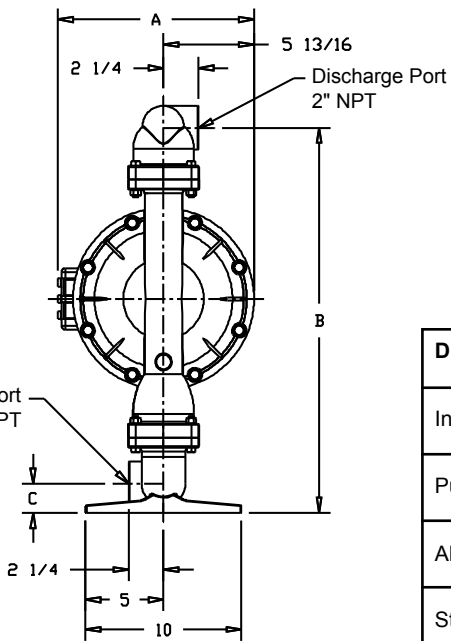

SIDE VIEW

Integral Muffler
1" NPT Exhaust Port
For Optional Muffler
Styles or Piping Exhaust
Air In Submerged
Applications

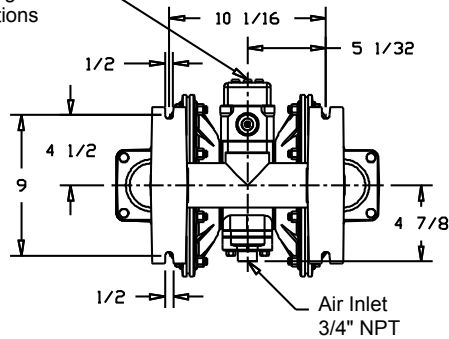

BOTTOM VIEW

Both Suction And
Discharge Ports Are
Available With
2" BSP Connection

Dimension	A	B	C	D	E	F
Integral Muffler	12 19/32					
Pulse Output Kit	12 19/32					
Aluminum		24 5/8	1 7/8	5/16	13 11/16	26 3/16
Stainless Steel		24 3/4	2	7/16	13 13/16	26 5/16
Mesh Muffler	15 1/8					
Sound Dampening Muffler	15 1/8					
Metal Muffler	14 11/16					

Metric Dimensions: M20 Metallic

Dimensions in Millimeters
Dimensional Tolerance: $\pm 3\text{mm}$

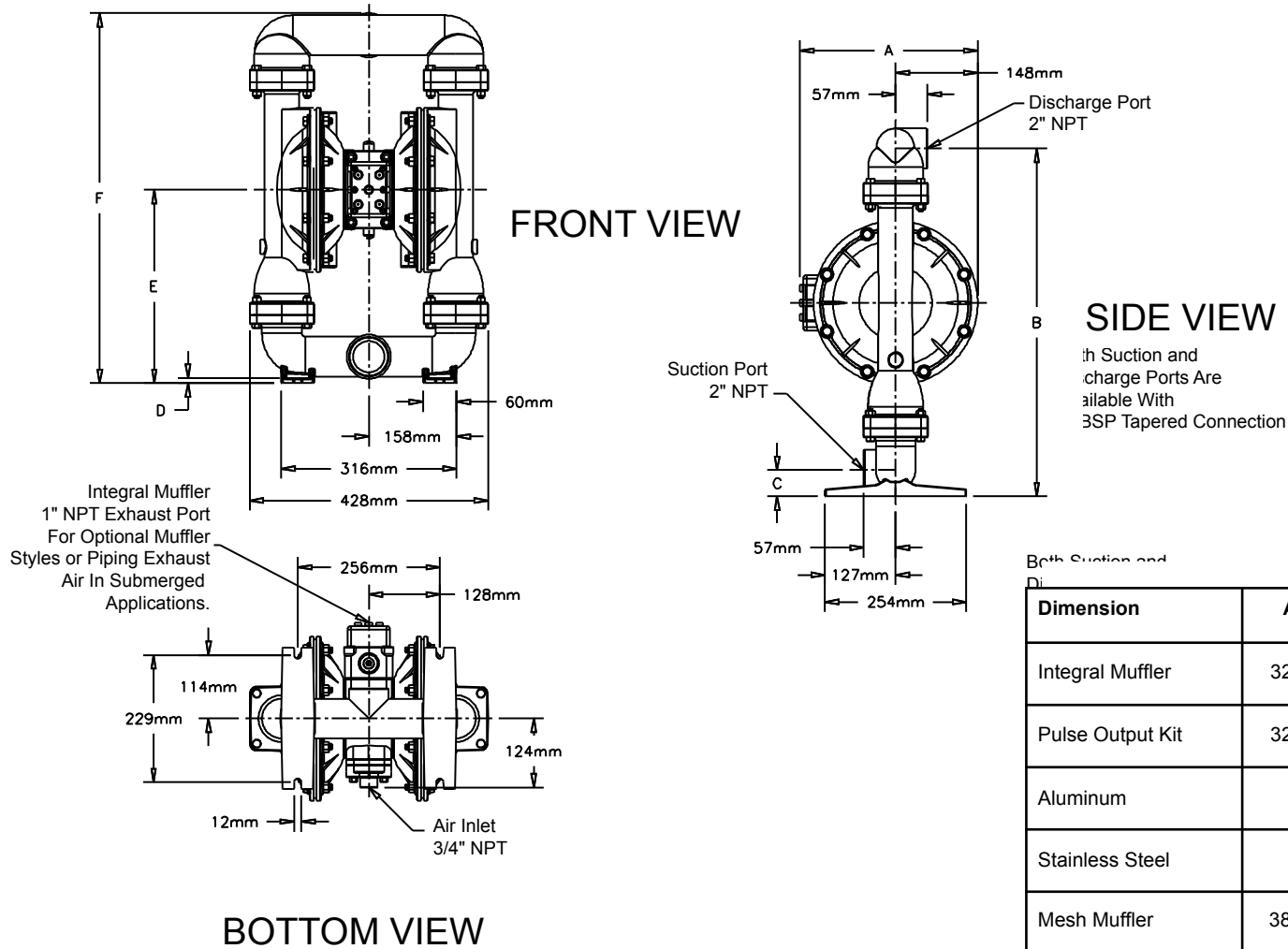

Dimension	A	B	C	D	E	F
Integral Muffler	320					
Pulse Output Kit	320					
Aluminum		625	47	8	348	665
Stainless Steel		629	51	12	351	669
Mesh Muffler	384					
Sound Dampening Muffler	384					
Metal Muffler	373					

PRINCIPLE OF PUMP OPERATION

This ball type check valve pump is powered by compressed air and is a 1:1 ratio design. The inner side of one diaphragm chamber is alternately pressurized while simultaneously exhausting the other inner chamber. This causes the diaphragms, which are connected by a common rod secured by plates to the centers of the diaphragms, to move in a reciprocating action. (As one diaphragm performs the discharge stroke the other diaphragm is pulled to perform the suction stroke in the opposite chamber.) Air pressure is applied over the entire inner surface of the diaphragm while liquid is discharged from the opposite side of the diaphragm. The diaphragm operates in a balanced condition during the discharge stroke which allows the pump to be operated at discharge heads over 200 feet (61 meters) of water.

For maximum diaphragm life, keep the pump as close to the liquid being pumped as possible. Positive suction head in excess of 10 feet of liquid (3.048 meters) may require a back pressure regulating device to maximize diaphragm life.

Alternate pressurizing and exhausting of the diaphragm chamber is performed by an externally mounted, pilot operated, four way spool type air distribution valve. When the spool shifts to one end of the valve body, inlet pressure is applied to one diaphragm chamber and the other diaphragm chamber exhausts. When the spool shifts to the opposite end of the valve body, the pressure to the chambers

is reversed. The air distribution valve spool is moved by a internal pilot valve which alternately pressurizes one end of the air distribution valve spool while exhausting the other end. The pilot valve is shifted at each end of the diaphragm stroke when a actuator plunger is contacted by the diaphragm plate. This actuator plunger then pushes the end of the pilot valve spool into position to activate the air distribution valve.

The chambers are connected with manifolds with a suction and discharge check valve for each chamber, maintaining flow in one direction through the pump.

INSTALLATION AND START-UP

Locate the pump as close to the product being pumped as possible. Keep the suction line length and number of fittings to a minimum. Do not reduce the suction line diameter.

For installations of rigid piping, short sections of flexible hose should be installed between the pump and the piping. The flexible hose reduces vibration and strain to the pumping system. A MARATHON surge suppressor is recommended to further reduce pulsation in flow.

AIR SUPPLY

Air supply pressure cannot exceed 125 psi (8.6 bar). Connect the pump air inlet to an air supply of sufficient capacity and pressure required for desired performance. When the air supply line is solid piping, use a short length of flexible hose not less than 1/2" (13mm) in diameter between the pump and the piping to reduce

strain to the piping. The weight of the air supply line, regulators and filters must be supported by some means other than the air inlet cap. Failure to provide support for the piping may result in damage to the pump. A pressure regulating valve should be installed to insure air supply pressure does not exceed recommended limits.

AIR VALVE LUBRICATION

The air distribution valve and the pilot valve are designed to operate WITHOUT lubrication. This is the preferred mode of operation. There may be instances of personal preference or poor quality air supplies when lubrication of the compressed air supply is required. The pump air system will operate with properly lubricated compressed air supply. Proper lubrication requires the use of an air line lubricator (available from MARATHON) set to deliver one drop of SAE 10 non-detergent oil for every 20 SCFM (9.4 liters/sec.) of air the pump consumes at the point of operation. Consult the pump's published Performance Curve to determine this.

AIR LINE MOISTURE

Water in the compressed air supply can create problems such as icing or freezing of the exhaust air, causing the pump to cycle erratically or stop operating. Water in the air supply can be reduced by using a point-of-use air dryer to supplement the user's air drying equipment. This device removes water from the compressed air supply and alleviates the icing or freezing problems.

AIR INLET AND PRIMING

To start the pump, open the air valve approximately 1/2" to 3/4" turn. After the pump primes, the air valve can be opened to increase air flow as desired. If opening the valve increases cycling rate, but does not increase the rate of flow, cavitation has occurred. The valve should be closed slightly to obtain the most efficient air flow to pump flow ratio.

BETWEEN USES

When the pump is used for materials that tend to settle out or solidify when not in motion, the pump should be flushed after each use to prevent damage. (Product remaining in the pump between uses could dry out or settle out. This could cause problems with the diaphragms and check valves at restart.) In freezing temperatures the pump must be completely drained between uses in all cases.

TYPICAL INSTALLATION GUIDE

For Metallic Pumps

Available from
MARATHON

- ① MTA2 or MTA50 Surge Suppressor
- ② 020-051-000 Filter/Regulator
- ③ 020-051-001 Lubricator



CAUTION
The air exhaust should be piped to an area for safe disposition of the product being pumped, in the event of a diaphragm failure.

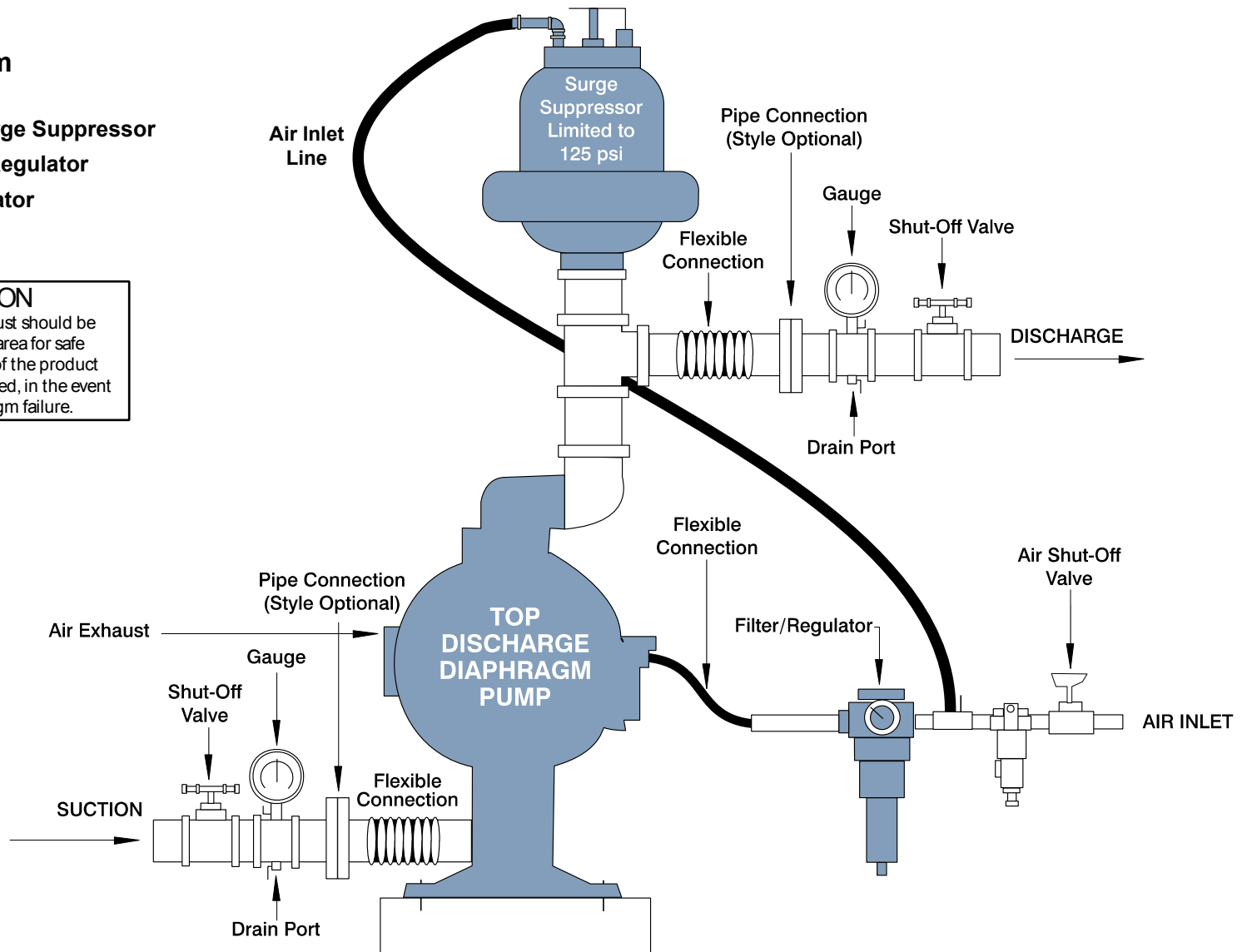

TROUBLESHOOTING

Possible Symptoms:

- Pump will not cycle.
- Pump cycles, but produces no flow.
- Pump cycles, but flow rate is unsatisfactory.
- Pump cycle seems unbalanced.
- Pump cycle seems to produce excessive vibration.

What to Check: Excessive suction lift in system.

Corrective Action: For lifts exceeding 20 feet (6 meters), filling the pumping chambers with liquid will prime the pump in most cases.

What to Check: Excessive flooded suction in system.

Corrective Action: For flooded conditions exceeding 10 feet (3 meters) of liquid, install a back pressure device.

What to Check: System head exceeds air supply pressure.

Corrective Action: Increase the inlet air pressure to the pump. Most diaphragm pumps are designed for 1:1 pressure ratio at zero flow.

What to Check: Air supply pressure or volume exceeds system head.

Corrective Action: Decrease inlet air pressure and volume to the pump as calculated on the published PERFORMANCE CURVE. Pump is cavitating the fluid by fast cycling.

What to Check: Undersized suction line.

Corrective Action: Meet or exceed pump connection recommendations shown on the DIMENSIONAL DRAWING.

What to Check: Restricted or undersized air line.

Corrective Action: Install a larger air line and connection. Refer to air inlet recommendations shown in your pump's SERVICE MANUAL.

What to Check: Check ESADS+Plus, the Externally Serviceable Air Distribution System of the pump.

Corrective Action: Disassemble and inspect the main air distribution valve, pilot valve and pilot valve actuators. Refer to the parts drawing and air valve section of the SERVICE MANUAL. Check for clogged discharge or closed valve before reassembly.

What to Check: Rigid pipe connections to pump.

Corrective Action: Install flexible connectors and a MARATHON Surge Suppressor.

What to Check: Blocked air exhaust muffler.

Corrective Action: Remove muffler screen, clean or de-ice and reinstall. Refer to the Air Exhaust section of your pump SERVICE MANUAL.

What to Check: Pumped fluid in air exhaust muffler.

Corrective Action: Disassemble pump chambers. Inspect for diaphragm rupture or loose diaphragm plate assembly. Refer to the Diaphragm Replacement section of your pump SERVICE MANUAL.

What to Check: Suction side air leakage or air in product.

Corrective Action: Visually inspect all suction side gaskets and pipe connections.

What to Check: Obstructed check valve.

Corrective Action: Disassemble the wet end of the pump and manually dislodge obstruction in the check valve pocket. Refer to the Check Valve section of the pump SERVICE MANUAL for disassembly instructions.

What to Check: Worn or misaligned check valve or check valve seat.

Corrective Action: Inspect check valves and seats for wear and proper seating. Replace if necessary. Refer to Check Valve section of the pump SERVICE MANUAL for disassembly instructions.

What to Check: Blocked suction line.

Corrective Action: Remove or flush obstruction. Check and clear all suction screens and strainers.

What to Check: Blocked discharge line.

Corrective Action: Check for obstruction or closed discharge line valves.

What to Check: Blocked pumping chamber.

Corrective Action: Disassemble and inspect the wetted chambers of the pump. Remove or flush any obstructions. Refer to the pump SERVICE MANUAL for disassembly instructions.

What to Check: Entrained air or vapor lock in one or both pumping chambers.

Corrective Action: Purge chambers through tapped chamber vent plugs. PURGING THE CHAMBERS OF AIR CAN BE DANGEROUS! Contact the MARATHON Technical Services Group before performing this procedure. Any model with top-ported discharge will reduce or eliminate problems with entrained air.

If your pump continues to perform below your expectations, contact your local MARATHON Distributor or factory Technical Services Group for a service evaluation.

WARRANTY

Refer to the enclosed MARATHON Warranty Certificate.

Recycling

Many components of MARATHON® Metallic AODD pumps are made of recyclable materials (see chart on page 10 for material specifications). We encourage pump users to recycle worn out parts and pumps whenever possible, after any hazardous pumped fluids are thoroughly flushed.

IMPORTANT SAFETY INFORMATION



⚠ IMPORTANT

Read these safety warnings and instructions in this manual completely, before installation and start-up of the pump. It is the responsibility of the purchaser to retain this manual for reference. Failure to comply with the recommendations stated in this manual will damage the pump, and void factory warranty.



⚠ CAUTION

Before pump operation, inspect all gasketed fasteners for looseness caused by gasket creep. Retorque loose fasteners to prevent leakage. Follow recommended torques stated in this manual.



⚠ WARNING

Before maintenance or repair, shut off the compressed air line, bleed the pressure, and disconnect the air line from the pump. The discharge line may be pressurized and must be bled of its pressure.



⚠ WARNING

In the event of diaphragm rupture, pumped material may enter the air end of the pump, and be discharged into the atmosphere. If pumping a product which is hazardous or toxic, the air exhaust must be piped to an appropriate area for safe disposition.



⚠ WARNING

Take action to prevent static sparking. Fire or explosion can result, especially when handling flammable liquids. The pump, piping, valves, containers or other miscellaneous equipment must be grounded. (See page 28)



⚠ WARNING

This pump is pressurized internally with air pressure during operation. Always make certain that all bolting is in good condition and that all of the correct bolting is reinstalled during assembly.



⚠ WARNING

When used for toxic or aggressive fluids, the pump should always be flushed clean prior to disassembly.



⚠ WARNING

Before doing any maintenance on the pump, be certain all pressure is completely vented from the pump, suction, discharge, piping, and all other openings and connections. Be certain the air supply is locked out or made non-operational, so that it cannot be started while work is being done on the pump. Be certain that approved eye protection and protective clothing are worn all times in the vicinity of the pump. Failure to follow these recommendations may result in serious injury or death.



⚠ WARNING

Airborne particles and loud noise hazards. Wear ear and eye protection.

Material Codes

The Last 3 Digits of Part Number

000	Assembly, sub-assembly; and some purchased items	180	Copper Alloy	378	High Density Polypropylene	601	PTFE (Bronze and moly filled)
010	Cast Iron	305	Carbon Steel, Black Epoxy Coated	379	Conductive Nitrile	602	Filled PTFE
012	Powered Metal	306	Carbon Steel, Black PTFE Coated	405	Cellulose Fibre	603	Blue Gylon
015	Ductile Iron	307	Aluminum, Black Epoxy Coated	408	Cork and Neoprene	604	PTFE
020	Ferritic Malleable Iron	308	Stainless Steel, Black PTFE Coated	425	Compressed Fibre	606	PTFE
025	Music Wire	309	Aluminum, Black PTFE Coated	426	Blue Gard	607	Envelon
080	Carbon Steel, AISI B-1112	310	PVDF Coated	440	Vegetable Fibre	608	Conductive PTFE
100	Alloy 20	330	Zinc Plated Steel	465	Fibre	610	PTFE Integral Silicon
110	Alloy Type 316 Stainless Steel	331	Chrome Plated Steel	500	Delrin 500	611	PTFE Integral FKM
111	Alloy Type 316 Stainless Steel (Electro Polished)	332	Aluminum, Electroless Nickel Plated	501	Delrin 570	632	Neoprene/Hytrel
112	Alloy C	333	Carbon Steel, Electroless Nickel Plated	502	Conductive Acetal, ESD-800	633	FKM (Fluorocarbon)/PTFE
113	Alloy Type 316 Stainless Steel (Hand Polished)	335	Galvanized Steel	503	Conductive Acetal, Glass-Filled	634	EPDM/PTFE
114	303 Stainless Steel	336	Zinc Plated Yellow Brass	505	Acrylic Resin Plastic	635	Neoprene/PTFE
115	302/304 Stainless Steel	337	Silver Plated Steel	506	Delrin 150	637	PTFE, FKM (Fluorocarbon)/PTFE
117	440-C Stainless Steel (Martensitic)	340	Nickel Plated	520	Injection Molded PVDF Natural color	638	PTFE, Hytrel/PTFE
120	416 Stainless Steel (Wrought Martensitic)	342	Filled Nylon	521	Conductive PVDF	639	Nitrile/TFE
123	410 Stainless Steel (Wrought Martensitic)	353	Geolast; Color: Black	540	Nylon	643	Santoprene/EPDM
148	Hardcoat Anodized Aluminum	354	Injection Molded #203-40 Santoprene- Duro 40D +/-5; Color: RED	541	Nylon	644	Santoprene/PTFE
149	2024-T4 Aluminum	355	Thermal Plastic	542	Nylon	650	Bonded Santoprene and PTFE
150	6061-T6 Aluminum	356	Hytrel	544	Nylon Injection Molded	654	Santoprene Diaphragm, PTFE Overlay Balls and seals
151	6063-T6 Aluminum	357	Injection Molded Polyurethane	550	Polyethylene	656	Santoprene Diaphragm and Check Balls/EPDM Seats
152	2024-T4 Aluminum (2023-T351)	358	Urethane Rubber (Some Applications) (Compression Mold)	551	Glass Filled Polypropylene	661	EPDM/Santoprene
154	Almag 35 Aluminum	359	Urethane Rubber	552	Unfilled Polypropylene		
155	356-T6 Aluminum	360	Nitrile Rubber. Color coded: RED	553	Unfilled Polypropylene		
156	356-T6 Aluminum	361	FDA Accepted Nitrile	555	Polyvinyl Chloride		
157	Die Cast Aluminum Alloy #380	363	FKM (Fluorocarbon). Color coded: YELLOW	556	Black Vinyl		
158	Aluminum Alloy SR-319	364	E.P.D.M. Rubber. Color coded: BLUE	557	Conductive Polypropylene		
159	Anodized Aluminum	365	Neoprene Rubber. Color coded: GREEN	558	Conductive HDPE		
162	Brass, Yellow, Screw Machine Stock	366	Food Grade Nitrile	559	Glass-Filled Conductive Polypropylene		
165	Cast Bronze, 85-5-5-5	368	Food Grade EPDM	570	Rulon II		
166	Bronze, SAE 660	370	Butyl Rubber. Color coded: BROWN	580	Ryton		
170	Bronze, Bearing Type, Oil Impregnated	371	Philthane (Tuftane)	590	Valox		
175	Die Cast Zinc	374	Carboxylated Nitrile	591	Nylatron G-S		
		375	Fluorinated Nitrile	592	Nylatron NSB		
				600	PTFE (virgin material) Tetrafluorocarbon (TFE)		

Delrin and Hytrel are registered tradenames of E.I. DuPont.

Gylon is a registered tradename of Garlock, Inc.

Nylatron is a registered tradename of Polymer Corp.

Santoprene is a registered tradename of Exxon Mobil Corp.

Rulon II is a registered tradename of Dixon Industries Corp.

Ryton is a registered tradename of Phillips Chemical Co.

Valox is a registered tradename of General Electric Co.

MARATHON, PortaPump and SludgeMaster are registered tradenames of Warren Rupp, Inc.

Composite Repair Parts Drawing

Available Service And Conversion Kits

- 476-227-000 AIR END KIT (Aluminum Center)**
Seals, O-ring, Gaskets, Retaining Rings, Air Valve Sleeve and Spool Set and Pilot Valve Assembly.
- 476-227-010 AIR END KIT (Use With Cast Iron Centers)**
- 476-227-110 AIR END KIT (Use With Stainless Steel Centers)**
- 476-170-558 AIR END KIT (Air Valve with Stroke Indicator Pin, Aluminum Center)**
Seals, O-ring, Gaskets, Retaining Rings, Air Valve Sleeve and Spool Set, and Pilot Valve Assembly.
- 476-042-360 WET END KIT**
Nitrile Diaphragms, Balls, and Seats.
- 476-042-354 WET END KIT**
Santoprene Diaphragms, Santoprene Balls and EPDM Seats.
- 476-042-365 WET END KIT**
Neoprene Diaphragms, Balls and Seats.
- 476-042-633 WET END KIT**
FKM Diaphragms, PTFE Balls and FKM Seats.
- 476-042-635 WET END KIT**
Neoprene Diaphragms, PTFE Overlay, PTFE Balls and PTFE Seats.
- 476-042-364 WET END KIT**
EPDM Diaphragms, Balls and Seats.
- 476-042-654 WET END KIT**
Santoprene Diaphragm, PTFE Overlays, PTFE Balls, PTFE Seats.
- 476-042-659 WETTED END KIT**
One-Piece Bonded PTFE/Nitrile Diaphragm, PTFE Balls, PTFE Seats.
- 475-216-000 MIDSECTION CONVERSION KIT**
(Replaces Aluminum Midsection With Cast Iron Components) Air Inlet Cap, Intermediate Bracket, Inner Chamber and Inner Diaphragm Plates.

Hardware Kits

- 475-200-330 Zinc Plated Capscrews, Washers, and Hex Nuts.
475-200-115 Stainless Steel Capscrews, Washers, and Hex Nuts.

**Electronic Leak Detector Kits

- 032-037-000 100-120/220-290 VAC
032-045-000 12-32 VDC

****Note: Pumps equipped with these components are not ATEX compliant**

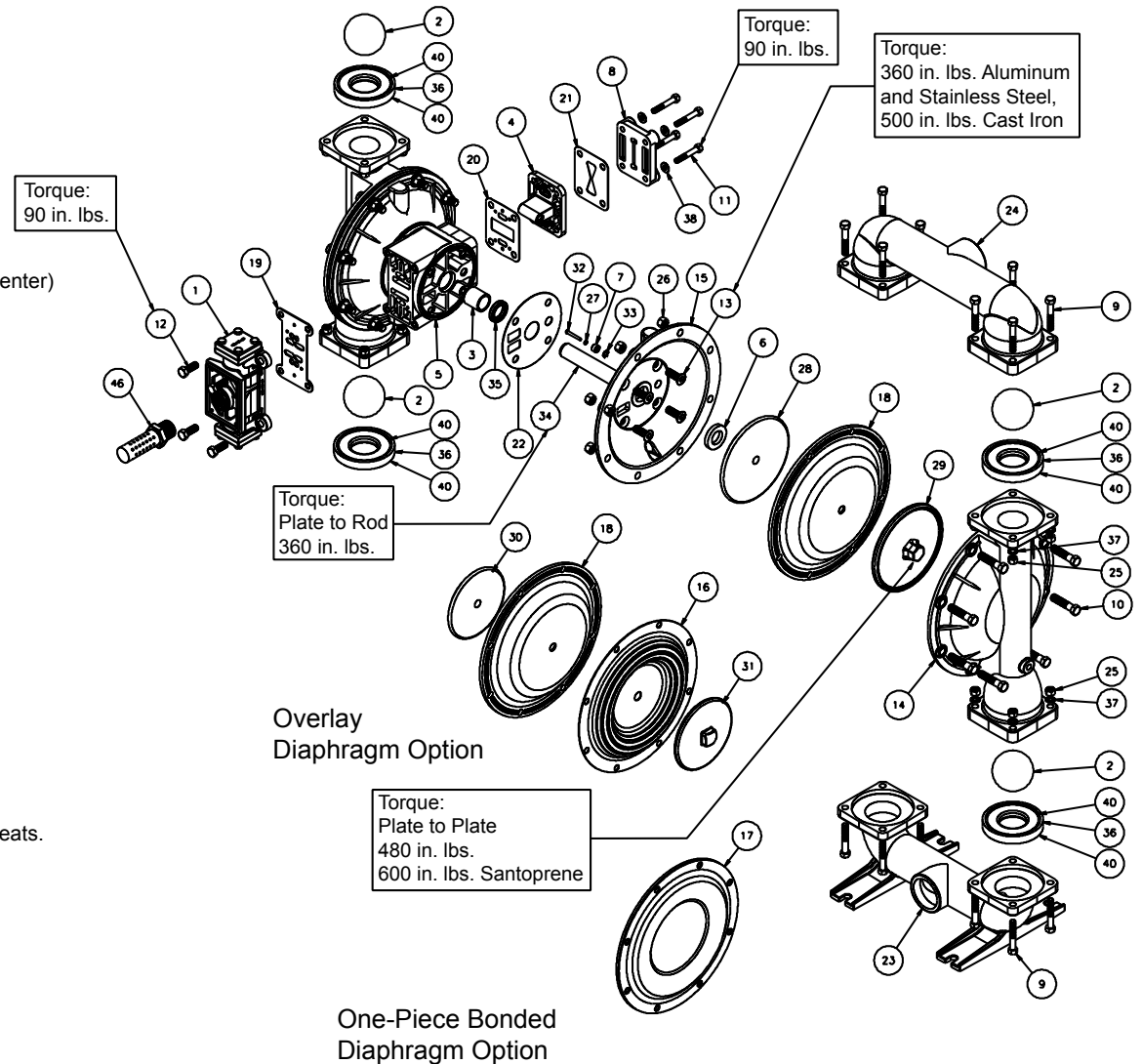

Composite Parts List



ITEM	PART NUMBER	DESCRIPTION	QTY	ITEM	PART NUMBER	DESCRIPTION	QTY
1	031-140-000	Air Valve Assembly w/Integral muffler (Cast Iron Centers Only)	1		518-145-010	Manifold, Suction	1
	031-141-000	Air Valve Assembly (Cast Iron Centers Only)	1		518-145-010E	Manifold, Suction 2" BSP Tapered	1
	▲ 031-146-000	Air Valve Assembly w/Integral muffler (Stroke Indicator Only)	1		518-145-110	Manifold, Suction	1
	▲ 031-147-000	Air Valve Assembly (Stroke Indicator Only)	1		518-145-110E	Manifold, Suction 2" BSP Tapered	1
	031-173-000	Air Valve Assembly w/Integral muffler	1	24	518-146-156	Manifold, Discharge	1
	031-173-001	Air Valve Assembly (with Stainless Steel Hardware)	1		518-146-156E	Manifold, Discharge 2" BSP Tapered	1
	▲ 031-183-000	Air Valve Assembly	1		518-146-010	Manifold, Discharge	1
	▲ 031-179-000	Air Valve Assembly (Cast Iron or Stainless Steel Centers Only)	1		518-146-010E	Manifold, Discharge 2" BSP Tapered	1
2	050-017-354	Ball, Check	4		518-146-110	Manifold, Discharge	1
	050-017-360	Ball, Check	4		518-146-110E	Manifold, Discharge 2" BSP Tapered	1
	050-017-360W	Ball, Check	4	25	545-005-115	Nut, Hex 3/8-16	16
	050-017-364	Ball, Check	4		545-005-330	Nut, Hex 3/8-16	16
	050-017-364W	Ball, Check	4	26	545-007-115	Nut, Hex 7/16-14	16
	050-017-365	Ball, Check	4		545-007-330	Nut, Hex 7/16-14	16
	050-017-365W	Ball, Check	4	27	560-001-379	O-Ring	2
	050-018-600	Ball, Check	4	28	612-192-157	Plate, Inner Diaphragm	2
3	070-006-170	Bushing	2		612-192-010	Plate, Inner Diaphragm	2
4	095-110-000	Pilot Valve Assembly	1		612-214-150	Plate, Inner Diaphragm	2
	095-095-110	Pilot Valve Assembly (Stainless Steel Centers Only)	1			(use with one-piece bonded diaphragm 286-118-000)	2
	095-110-558	Pilot Valve Assembly (Cast Iron Centers Only)	1	29	612-194-157	Plate, Outer Diaphragm Assembly	2
5	114-024-157	Intermediate Bracket	1		612-194-010	Plate, Outer Diaphragm Assembly	2
	114-024-010	Intermediate Bracket	1		612-194-110	Plate, Outer Diaphragm Assembly	2
	114-024-110	Intermediate Bracket (Stainless Steel Centers Only)	1	30	612-195-157	Plate, Inner Diaphragm (used with 286-020-604)	2
6	132-035-360	Bumper, Diaphragm	2		612-195-010	Plate, Inner Diaphragm (used with 286-020-604)	2
7	135-034-506	Bushing, Plunger	2	31	612-039-010	Plate, Outer Diaphragm Assembly (used with 286-020-604)	2
8	165-116-157	Cap, Air Inlet Assembly	1		612-097-110	Plate, Outer Diaphragm Assembly (used with 286-020-604)	2
	165-116-010	Cap, Air Inlet Assembly	1		612-039-157	Plate, Outer Diaphragm Assembly (used with 286-020-604)	2
	165-116-110	Cap, Air Inlet Assembly (Stainless Steel Centers Only)	1	32	620-020-115	Plunger, Actuator	2
9	170-052-115	Capscrew, Hex Hd 3/8-16 X 2.25	16	33	675-042-115	Ring, Retaining	2
	170-052-330	Capscrew, Hex Hd 3/8-16 X 2.25	16	34	685-058-120	Rod, Diaphragm	1
10	170-060-115	Capscrew, Hex Hd 7/16-14 X 2.00	16	35	720-004-360	Seal, Diaphragm Rod	2
	170-060-330	Capscrew, Hex Hd 7/16-14 X 2.00	16		722-040-550	Seat, Check Ball	4
11	170-069-115	Capscrew, Hex Hd 5/16-18 X 1.75	4	36	722-040-360	Seat, Check Ball	4
	170-069-330	Capscrew, Hex Hd 5/16-18 X 1.75	4		722-040-363	Seat, Check Ball	4
12	171-053-115	Capscrew, Soc Hd 3/8-16 X 2.50	4		722-040-364	Seat, Check Ball	4
		(Stroke Indicator Only)			722-040-365	Seat, Check Ball	4
	171-053-330	Capscrew, Soc Hd 3/8-16 X 2.50	4		722-040-080	Seat, Check Ball (seals required see item 40)	4
		(Stroke Indicator Only)			722-040-110	Seat, Check Ball (seals required see item 40)	4
	170-006-115	Capscrew, Hex HD 3/8-16 X 1.00	4		722-040-150	Seat, Check Ball (seals required see item 40)	4
	170-006-330	Capscrew, Hex HD 3/8-16 X 1.00	4		722-040-600	Seat, Check Ball	4
13	171-059-115	Capscrew, Soc Hd 7/16-14 X 1.25	8	37	900-005-115	Washer, Lock	16
	171-059-330	Capscrew, Soc Hd 7/16-14 X 1.25	8		900-005-330	Washer, Lock	16
	171-011-115	Capscrew, Soc Hd 1/2-13 x 1.00 (Stainless Steel Centers Only)	8	38	901-038-115	Washer, Flat 5/16	4
14	196-167-156/157	Chamber, Outer	2		901-038-330	Washer, Flat 5/16	4
	196-167-010	Chamber, Outer	2	39	901-048-115	Washer, Flat 3/8 (Stroke Indicator Only)	4
	196-167-110	Chamber, Outer	2		901-048-330	Washer, Flat 3/8 (Stroke Indicator Only)	4
15	196-168-157	Chamber, Inner	2	40	560-106-360	Seal (O-Ring) (See item 36)	8
	196-168-010	Chamber, Inner	2		560-106-363	Seal (O-Ring) (See item 36)	8
	196-168-110	Chamber, Inner (Stainless Steel Centers Only)	2		560-106-364	Seal (O-Ring) (See item 36)	8
16	286-020-604	Diaphragm, Overlay	2		560-106-365	Seal (O-Ring) (See item 36)	8
17	286-118-000	Diaphragm, One-Piece Bonded	2		720-060-608	Seal (O-Ring) (See item 36)	8
18	286-007-354	Diaphragm	2	▲ 46	530-033-000	Metal Muffler (for other muffler options see pg. 24)	1
	286-007-360	Diaphragm	2				
	286-007-363	Diaphragm	2				
	286-007-364	Diaphragm	2				
	286-007-365	Diaphragm	2				
19	360-093-360	Gasket, Air Valve	1				
20	360-114-360	Gasket, Pilot Valve	1				
21	360-104-379	Gasket, Air Inlet	1				
22	360-105-360	Gasket, Inner Chamber	2				
23	518-145-156	Manifold, Suction	1				
	518-145-156E	Manifold, Suction 2" BSP Tapered	1				

Parts not shown used with Raised Face Flange Porting Option.

170-035-330	Hex Cap Screw	4
326-052-080	Mounting Bracket	2
334-115-110	2" Raised Face, 150# ANSI Flange	2
538-024-110	Pipe Nipple 2" NPT x 2½"	2
545-007-330	Hex Nut	4
900-006-330	Lock Washer	4
901-022-330	Flat Washer	8

Air Valve Servicing, Assembly Drawing & Parts List

(Use With Aluminum Centers Only)

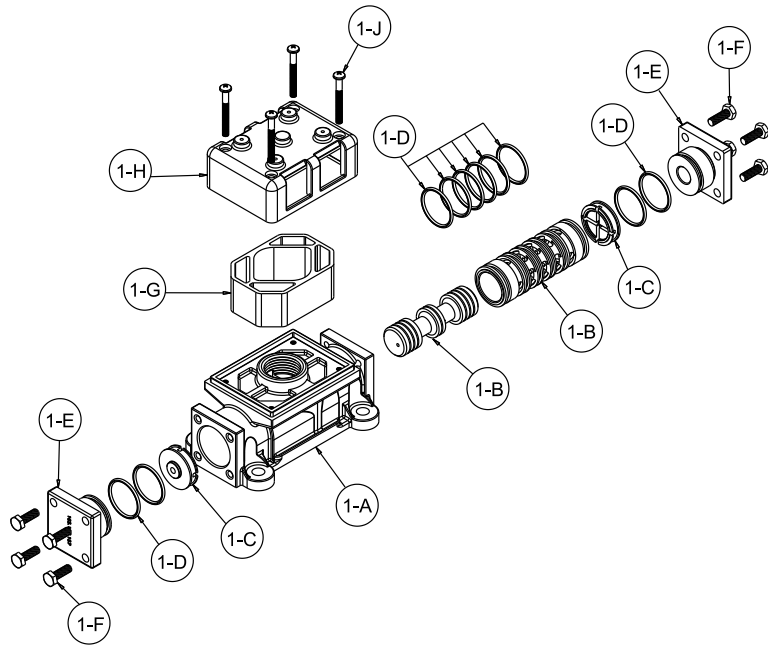

AIR VALVE ASSEMBLY PARTS LIST

Item	Part Number	Description	Qty
1	031-173-000	Air Valve Assembly	1
1-A	095-109-157	Body, Air Valve	1
1-B	031-139-000	Sleeve and Spool Set	1
1-C	132-029-357	Bumper	2
1-D	560-020-360	O-Ring	10
1-E	165-127-157	Cap, End	2
1-F	170-032-330	Hex Head Capscrew 1/4-20 x .75	8
1-G	530-028-550	Muffler	1
1-H	165-096-551	Muffler Cap	1
1-J	706-026-330	Machine Screw	4

**AIR VALVE ASSEMBLY PARTS LIST

1	031-173-001	Air Valve Assembly	1
Consists of all components above except:			
1-F	170-032-115	Hex Head Capscrew 1/4-20 x .75	8
1-J	706-026-115	Machine Screw	4

****Note:** Pumps equipped with this valve assembly are not ATEX compliant

AIR DISTRIBUTION VALVE SERVICING

To service the air valve first shut off the compressed air, bleed pressure from the pump, and disconnect the air supply line from the pump.

Step #1: See COMPOSITE REPAIR PARTS DRAWING.

Using a 9/16" wrench or socket, remove the four hex capscrews (items 12). Remove the air valve assembly from the pump.

Remove and inspect gasket (item 19) for cracks or damage. Replace gasket if needed.

Step #2: Disassembly of the air valve.

Using a 7/16" wrench or socket, remove the eight hex capscrews (items 1-F) that

fasten the end caps to the valve body. Next remove the two end caps (items 1-E). Inspect the two o-rings (items 1-D) on each end cap for damage or wear. Replace the bumpers as needed.

Remove the bumpers (items 1-C). Inspect the bumpers for damage or wear. Replace the bumpers as needed.

Remove the spool (part of item 1-B) from the sleeve. Be careful not to scratch or damage the outer diameter of the spool. Wipe spool with a soft cloth and inspect for scratches or wear.

Inspect the inner diameter of the sleeve (part of item 1-B) for dirt, scratches, or other contaminants. Remove the sleeve if needed and replace with a new sleeve and spool set (item 1-B).

Step #3: Reassembly of the air valve.

Install one bumper (item 1-C) and one end cap (item 1-E), with two o-rings (items 1-D), and fasten with four hex capscrews (items 1-F) to the valve body (item 1-A).

Remove the new sleeve and spool set (item 1-B) from the plastic bag. Carefully remove the spool from the sleeve. Install the six o-rings (item 1-D) into the six grooves on the sleeve. Apply a light coating of grease to the o-rings before installing the sleeve into the valve body (item 1-A), align the slots in the sleeve with the slots in the valve body. Insert the spool into the sleeve. Be careful not to scratch or damage the spool during installation. Carefully insert the sleeve into the bumper and end cap (with o-rings) and fasten with the remaining hex capscrews.

Fasten the air valve assembly (item 1) and gasket to the pump. Connect the compressed air line to the pump. The pump is now ready for operation.



! IMPORTANT

Read these instructions completely, before installation and start-up. It is the responsibility of the purchaser to retain this manual for reference. Failure to comply with the recommendations stated in this manual will damage the pump, and void factory warranty.

Air Valve Servicing, Assembly Drawing & Parts List

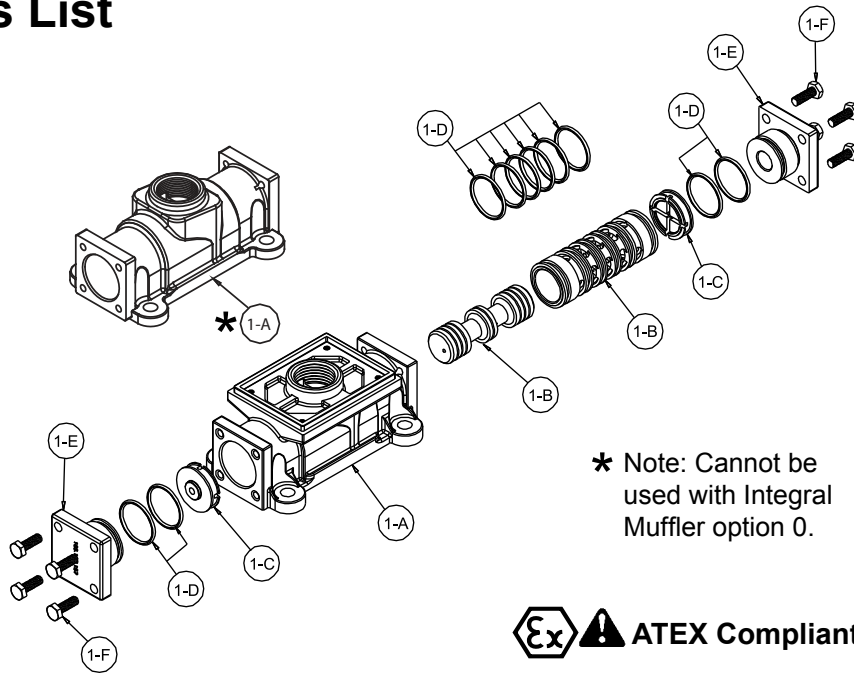

AIR VALVE ASSEMBLY PARTS LIST (USE W/ALUMINUM CENTERS ONLY)

Item	Part Number	Description	Qty
⚠️ 1	031-183-000	Air Valve Assembly	1
1-A	095-109-157	Body, Air Valve	1
1-B	031-139-000	Sleeve and Spool Set	1
1-C	132-029-357	Bumper	2
1-D	560-020-360	O-Ring	10
1-E	165-127-157	Cap, End	2
1-F	170-032-330	Hex Head Capscrew 1/4-20 x .75	8

AIR VALVE ASSEMBLY PARTS LIST

⚠️ 1	031-183-001	Air Valve Assembly	1
Consists of all components above except:			
1-F	170-032-115	Hex Head Capscrew 1/4-20 x .75	8

AIR VALVE ASSEMBLY PARTS LIST (Use w/Cast Iron and Stainless Steel centers)

Item	Part Number	Description	Qty
⚠️ 1	031-179-000	Air Valve Assembly	1
1-A	095-109-110 *	Body, Air Valve	1
1-B	031-139-000	Sleeve and Spool Set	1
1-C	132-029-357	Bumper	2
1-D	560-020-379	O-Ring	10
1-E	165-127-110	Cap, End	2
1-F	170-032-115	Hex Head Capscrew 1/4-20 x .75	8

AIR DISTRIBUTION VALVE SERVICING

To service the air valve first shut off the compressed air, bleed pressure from the pump, and disconnect the air supply line from the pump.

Step #1: See COMPOSITE REPAIR PARTS DRAWING.

Using a 9/16" wrench or socket, remove the four hex capscrews (items 12). Remove the air valve assembly from the pump.

Remove and inspect gasket (item 19) for cracks or damage. Replace gasket if needed.

Step #2: Disassembly of the air valve.

Using a 7/16" wrench or socket, remove the eight hex capscrews (items 1-F) that

fasten the end caps to the valve body. Next remove the two end caps (items 1-E). Inspect the two o-rings (items 1-D) on each end cap for damage or wear. Replace the o-rings as needed.

Remove the bumpers (items 1-C). Inspect the bumpers for damage or wear. Replace the bumpers as needed.

Remove the spool (part of item 1-B) from the sleeve. Be careful not to scratch or damage the outer diameter of the spool. Wipe spool with a soft cloth and inspect for scratches or wear.

Inspect the inner diameter of the sleeve (part of item 1-B) for dirt, scratches, or other contaminants. Remove the sleeve if needed and replace with a new sleeve and spool set (item 1-B).

Step #3: Reassembly of the air valve.

Install one bumper (item 1-C) and one end cap (item 1-E), with two o-rings (items 1-D), and fasten with four hex capscrews (items 1-F) to the valve body (item 1-A).

Remove the new sleeve and spool set (item 1-B) from the plastic bag. Carefully remove the spool from the sleeve. Install the six o-rings (item 1-D) into the six grooves on the sleeve. Apply a light coating of grease to the o-rings before installing the sleeve into the valve body (item 1-A), align the slots in the sleeve with the slots in the valve body. Insert the spool into the sleeve. Be careful not to scratch or damage the spool during installation. Carefully insert the sleeve into the bumper and end cap (with o-rings) and fasten with the remaining hex capscrews.

Fasten the air valve assembly (item 1) and gasket to the pump. Connect the compressed air line to the pump. The pump is now ready for operation.



⚠️ IMPORTANT

Read these instructions completely, before installation and start-up. It is the responsibility of the purchaser to retain this manual for reference. Failure to comply with the recommendations stated in this manual will damage the pump, and void factory warranty.

Air Valve with Stroke Indicator Assembly

Drawing, Parts List

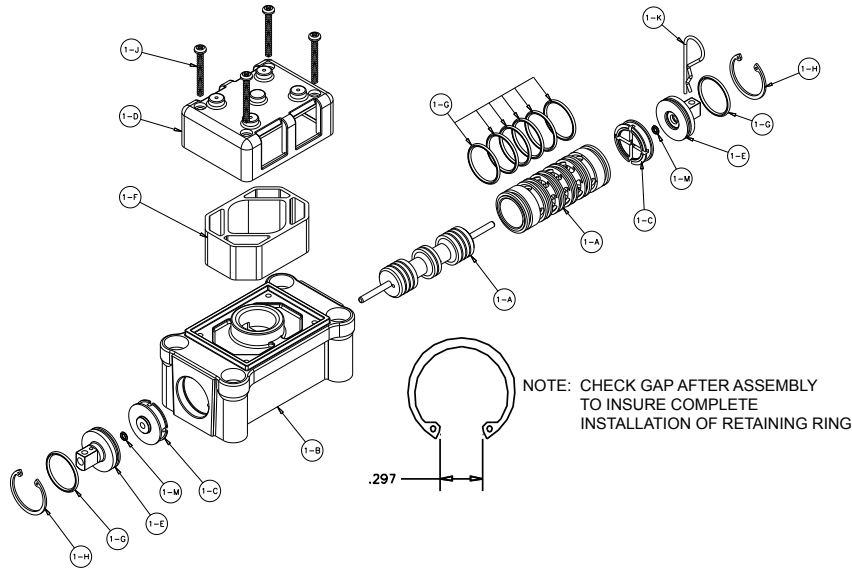

AIR DISTRIBUTION VALVE WITH STROKE INDICATOR OPTION SERVICING

To service the air valve first shut off the compressed air supply, bleed the pressure from the pump, and disconnect the air supply line from the pump.

Step #1: See COMPOSITE REPAIR PARTS DRAWING.

Using a 5/16" Allen wrench, remove the four hex socket capscrews (item 12) and four flat washers (item 39). Remove the air valve assembly from the pump.

Remove and inspect gasket (item 19) for cracks or damage. Replace gasket if needed.

Step #2: Disassembly of the air valve.

To access the internal air valve components first remove the two retaining rings (item 1-H) from each end of the air valve assembly using clip ring pliers.

Next remove the two end caps (item 1-E). Inspect the o-ring (items 1-G and 1-M) for cuts or wear. Replace the o-rings if necessary.

Remove the two bumpers (item 1-C). Inspect the bumpers for cut, wear or abrasion. Replace if necessary.

Remove the spool (part of item 1-A) from the sleeve. Be careful not to scratch or damage the outer diameter of the spool. Wipe spool with a soft cloth and inspect for scratches or wear.

Inspect the inner diameter of the sleeve (part of item 1-A) for dirt, scratches, or other contaminants. Remove the sleeve if needed and replace with a new sleeve and spool set (item 1-A).

Step #3: Reassembly of the air valve.

Install one bumper (item 1-C) and one end cap (item 1-E) with o-rings (item 1-G and 1-M) into one end of the air valve body (item 1-B). Install one retaining ring (item 1-H), into the groove on the same end. Insert the safety clip (item 1-K) through the smaller unthreaded hole in the endcap.

Remove the new sleeve and spool set (item 1-A) from the plastic bag. Carefully remove the spool from the sleeve. Install the six o-rings (item 1-G) into the six grooves on the sleeve. Apply a light coating of grease to the o-rings before installing the sleeve into the valve body (item 1-B). Align the slots in the sleeve with the slots in the valve body. Insert the spool into the sleeve. Be careful not to scratch or damage the spool during installation. Push the spool in until the pin touches the safety clip on the opposite end.

Install the remaining bumper, end cap with o-rings and retaining ring.

AIR VALVE ASSEMBLY PARTS LIST

Item	Part Number	Description	Qty
⚠ 1	031-146-000	Air Valve Assembly	1
1-A	031-143-000	Sleeve and Spool Set	1
1-B	095-094-559	Body, Air Valve	1
1-C	132-029-552	Bumper	2
1-D	165-096-559	Cap, Muffler	1
1-E	165-098-147	Cap, End	2
1-F	530-028-550	Muffler	1
1-G	560-020-360	O-Ring	8
1-H	675-044-115	Ring, Retaining	2
1-J	710-015-115	Screw, Self Tapping	4
1-K	210-008-330	Clip, Safety	1
1-M	560-029-360	O-Ring	2

For Pumps with Alternate Mesh, Sound Dampening Mufflers or Piped Exhaust:

⚠ 1	031-147-000	Air Valve Assembly	1
			(includes all items on 031-146-000 minus 1-D, 1-F, & 1-J).



Fasten the air valve assembly (item 1) and gasket (item 19) to the pump.

Connect the compressed air line to the pump. Remove the safety clip. The pump is now ready for operation.



⚠ IMPORTANT

Read these instructions completely, before installation and start-up. It is the responsibility of the purchaser to retain this manual for reference. Failure to comply with the recommendations stated in this manual will damage the pump, and void factory warranty.

Air Valve Assembly Drawing, Parts List

(Use With Cast Iron Centers Only)

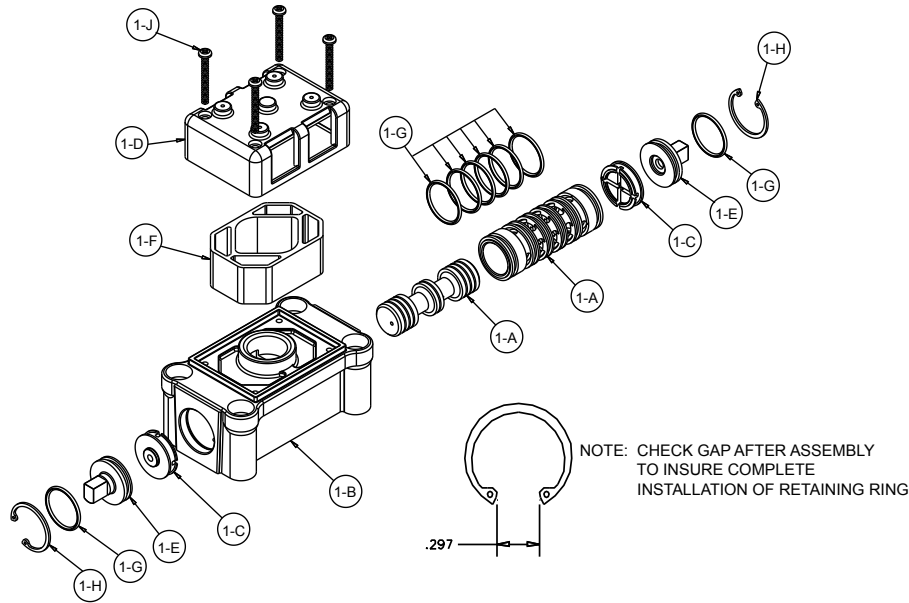

AIR VALVE ASSEMBLY PARTS LIST

Item	Part Number	Description	Qty
** 1	031-140-000	Air Valve Assembly	1
1-A	031-139-000	Sleeve and Spool Set	1
1-B	095-094-551	Body, Air Valve	1
1-C	132-029-552	Bumper	2
1-D	165-096-551	Cap, Muffler	1
1-E	165-115-558	Cap, End	2
1-F	530-028-550	Muffler	1
1-G	560-020-360	O-Ring	8
1-H	675-044-115	Ring, Retaining	2
1-J	710-015-115	Screw, Self Tapping	4

For Pumps with Alternate Mesh or Piped Exhaust:

** 1	031-141-000	Air Valve Assembly	1
(includes all items on 031-140-000 minus 1-D, 1-F, & 1-J)			

****Note: Pumps equipped with this valve assembly are not ATEX compliant**

AIR DISTRIBUTION VALVE OPTION SERVICING

To service the air valve first shut off the compressed air supply, bleed the pressure from the pump, and disconnect the air supply line from the pump.

Step #1: See COMPOSITE REPAIR PARTS DRAWING.

Using a 5/16" Allen wrench, remove the four hex socket capscrews (item 12) and four flat washers (item 39). Remove the air valve assembly from the pump.

Remove and inspect gasket (item 19) for cracks or damage. Replace gasket if needed.

Step #2: Disassembly of the air valve.

To access the internal air valve components first remove the two retaining rings (item 1-H) from each end of the air valve assembly using clip ring pliers.

Next remove the two end caps (item 1-E). Inspect the o-ring (items 1-G) for cuts or wear. Replace the o-rings if necessary.

Remove the spool (part of item 1-A) from the sleeve. Be careful not to scratch or damage the outer diameter of the spool. Wipe spool with a soft cloth and inspect for scratches or wear.

Inspect the inner diameter of the sleeve (part of item 1-A) for dirt, scratches, or other contaminants. Remove the sleeve if needed and replace with a new sleeve and spool set (item 1-A).

Step #3: Reassembly of the air valve.

Install one end cap (item 1-E) with o-ring (item 1-G) into one end of the air valve body (item 1-B). Install one retaining ring (item 1-H), into the groove on the same end.

Remove the new sleeve and spool set (item 1-A) from the plastic bag. Carefully remove the spool from the sleeve. Install the six o-rings (item 1-G) into the six grooves on the sleeve. Apply a light coating of grease to the o-rings before installing the sleeve into the valve body (item 1-B). Align the slots in the sleeve with the slots in the valve body. Insert the spool into the sleeve. Be careful not to scratch or damage the spool during installation. Push the spool in until it touches the bumper on the opposite end.

Install the remaining end cap with

o-rings and retaining ring.

Fasten the air valve assembly (item 1) and gasket (item 19) to the pump.

Connect the compressed air line to the pump. Remove the safety clip. The pump is now ready for operation.



! IMPORTANT

Read these instructions completely, before installation and start-up. It is the responsibility of the purchaser to retain this manual for reference. Failure to comply with the recommendations stated in this manual will damage the pump, and void factory warranty.

Solenoid Shifted Air Valve Drawing

SOLENOID SHIFTED AIR VALVE PARTS LIST

(Includes all items used on Composite Repair Parts List except as shown)

Item	Part Number	Description	Qty
41	893-097-000	Solenoid Valve, NEMA4	1
42	219-001-000	Solenoid Coil, 24VDC	1
	219-004-000	Solenoid Coil, 24VAC/12VDC	1
	219-002-000	Solenoid Coil, 120VAC	1
	219-003-000	Solenoid Coil, 240VAC	1
43	241-001-000	Connector, conduit	1
	241-003-000	Conduit Connector with Suppression Diode (DC Only)	1
44	170-029-330	Capscrew, Hex HD 5/16-18 x 1.25	4
45	618-051-150	Plug	2

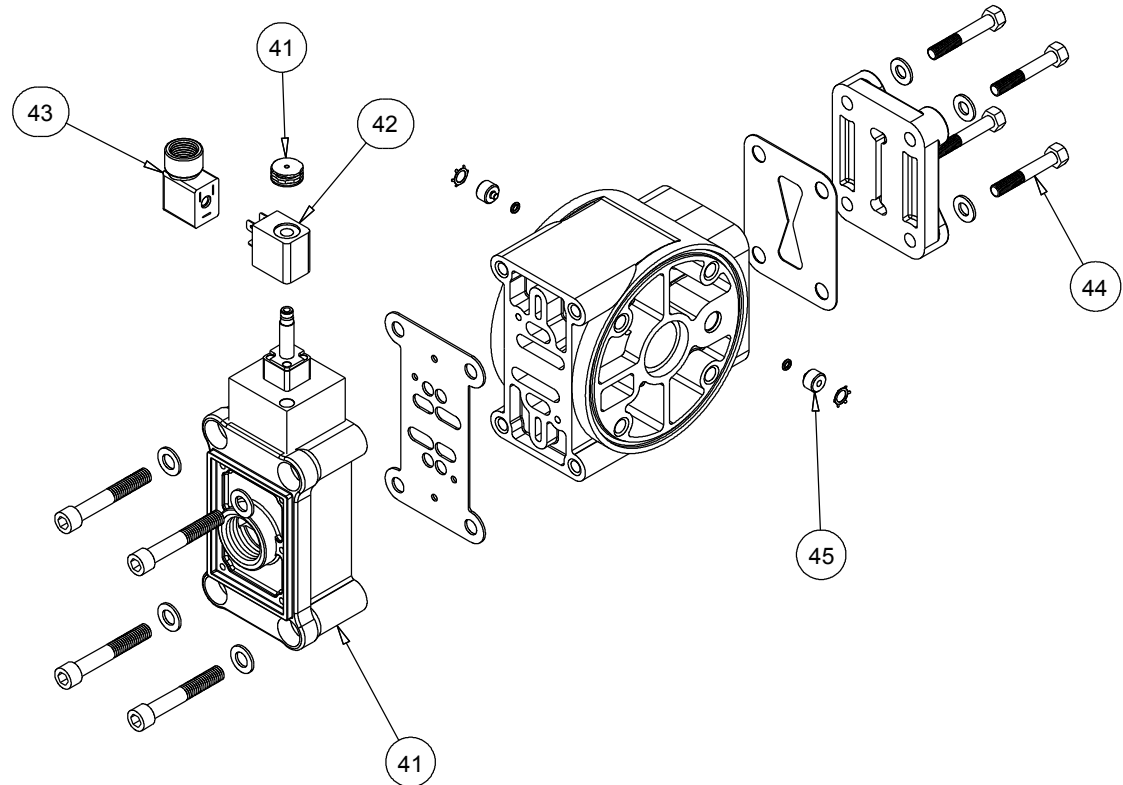

IEC EEX m T4



△ For Explosion Proof Solenoid Coils used in North America and outside the European Union.

42	219-009-001	Solenoid Coil, 120VAC 60 Hz	1
	219-009-002	Solenoid Coil, 240VAC 60 Hz	1
	219-009-003	Solenoid Coil, 12VDC	1
	219-009-004	Solenoid Coil, 24VDC	1
	219-009-005	Solenoid Coil, 110VAC 50 Hz	1
	219-009-006	Solenoid Coil, 230VAC 50 Hz	1

Note: Item 43 (Conduit Connector) is not required



II 2G EEx m c II T5
II 3/2 G Ex m c II T5
II 2D c IP65 T100°C

* ◆ For ATEX Compliant Solenoid Coils used in the European Union

219-011-001	Solenoid Coil, Single mounting 12 VDC, 3.3W / 267mA	1
219-011-002	Solenoid Coil, Single mounting 24 VDC, 3.3W / 136mA	1
219-011-003	Solenoid Coil, Single mounting 110/120 VAC, 3.4W / 29mA	1
219-011-004	Solenoid Coil, Single mounting 220/240 VAC, 3.4W / 15mA	1

Note: Item 35 (Conduit Connector) is not required

Compressed Air Temperature Range: Maximum Ambient Temperature to plus 50°C

*Special Conditions For Safe Use

A fuse corresponding to its rated current (max. $3 \cdot I_{rat}$ according IEC 60127-2-1) or a motor protecting switch with short-circuit and thermal instantaneous tripping (set to rated current) shall be connected in series to each solenoid as short circuit protection. For very low rated currents of the solenoid the fuse of lowest current value according to the indicated IEC standard will be sufficient. The fuse may be accommodated in the associated supply unit or shall be separately arranged. The rated voltage to the fuse shall be equal to or greater than the stated rated voltage of the magnet coil. The breakage capacity of the fuse-link shall be as high as or higher than the maximum expected short circuit current at the location of the installation (usually 1500 A). A maximum permissible ripple of 20% is valid for all magnets of direct-current design.

SOLENOID SHIFTED AIR DISTRIBUTION VALVE OPTION

MARATHON's solenoid shifted, air distribution valve option utilizes electrical signals to precisely control your MARATHON's speed. The solenoid coil is connected to the MARATHON Solenoid Rate Controller/Batch Control, or a customer - supplied control. Compressed air provides the pumping power, while electrical signals control pump speed (pumping rate).

OPERATION

The Solenoid Shifted MARATHON has a solenoid operated, air distribution valve in place of the standard MARATHON's pilot operated, air distribution valve. Where a pilot valve is normally utilized to cycle the pump's air distribution valve, an electric solenoid is utilized. As the solenoid is powered, one of the pump's air chambers is pressurized while the other chamber is exhausted. When electric power is turned off, the solenoid shifts and the pressurized chamber is exhausted while the other chamber is pressurized. By alternately applying and removing power to the solenoid, the pump cycles much like a standard MARATHON pump, with one exception. This option provides a way to precisely control and monitor pump speed.

BEFORE INSTALLATION

Before wiring the solenoid, make certain it is compatible with your system voltage.

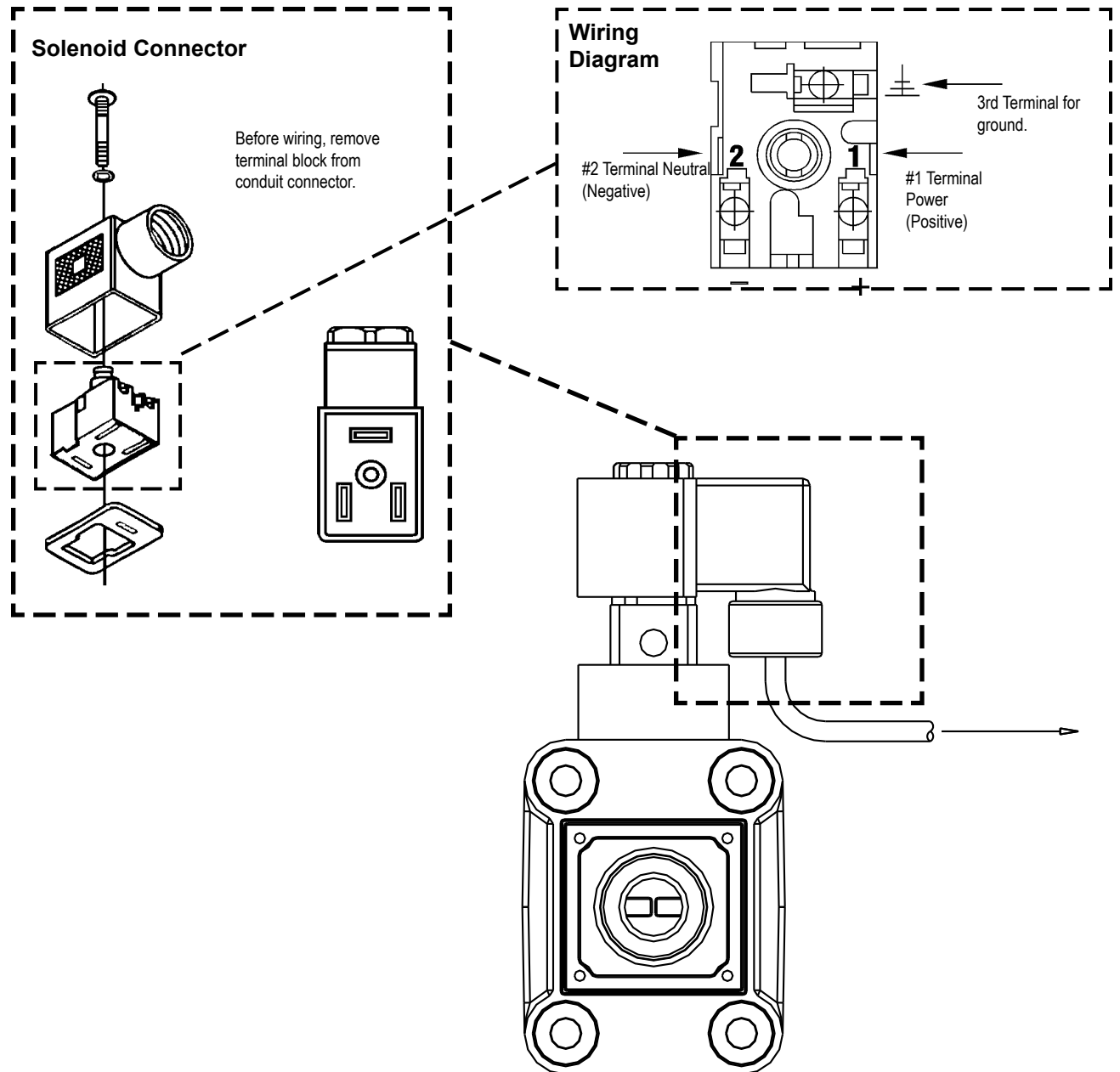

Diaphragm Service Drawing, with Overlay

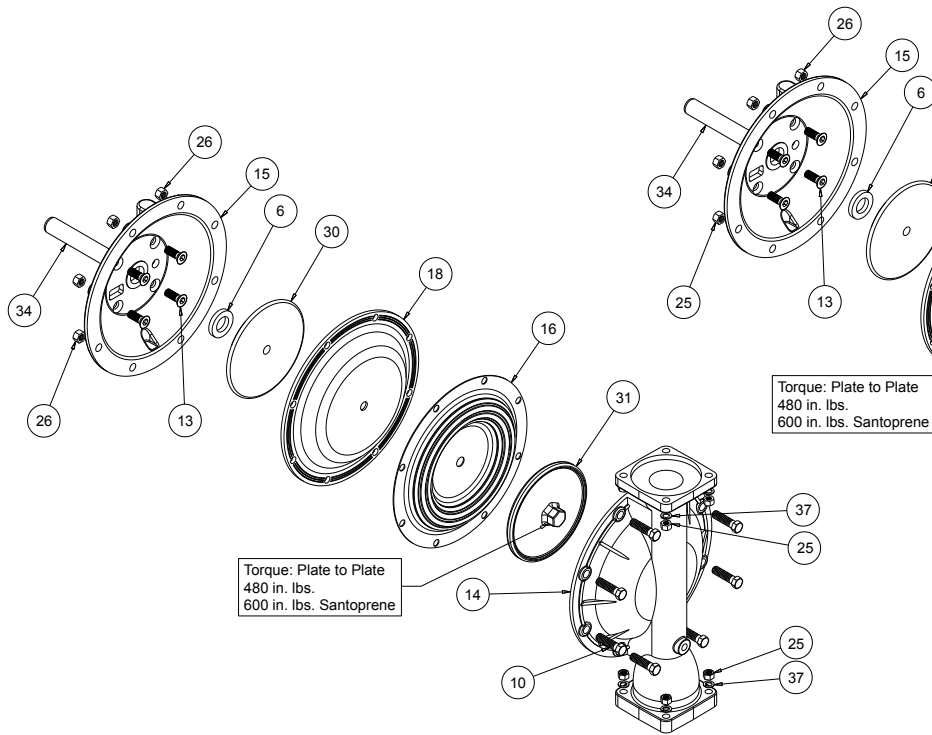

Diaphragm Service Drawing, Non-Overlay

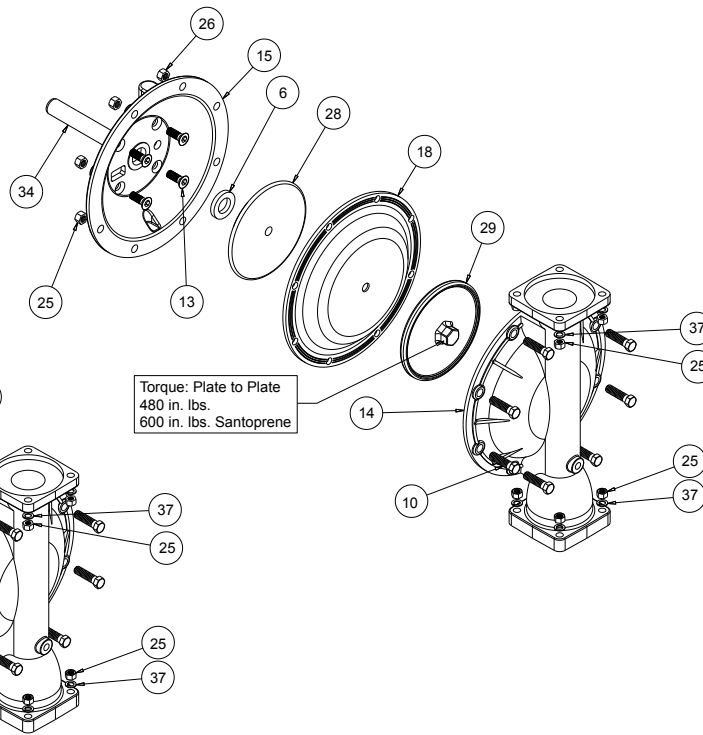

One-Piece Bonded *Diaphragm Service Drawing

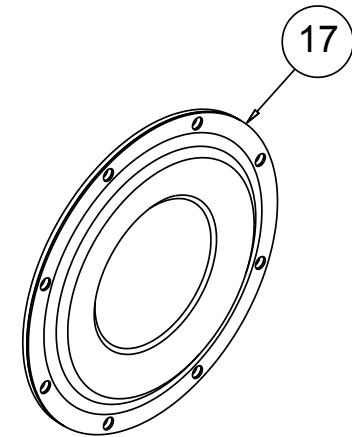

***AVAILABLE FOR FIELD CONVERSION FROM OVERLAY
TO ONE-PIECE BONDED DIAPHRAGM KITS:**

Kit: 475-253-000
 2 286-118-000 One-Piece Diaphragm
 2 612-214-150 Inner Plates

DIAPHRAGM SERVICING

To service the diaphragms first shut off the suction, then shut off the discharge lines to the pump. Shut off the compressed air supply, bleed the pressure from the pump, and disconnect the air supply line from the pump. Drain any remaining liquid from the pump.

Step #1: See the pump assembly drawing, and the diaphragm servicing illustration.

Using a 9/16" wrench or socket, remove the 16 capscrews (item 9), hex nuts, and lockwashers that fasten the manifolds (items 23 & 24) to the outer chambers (item 14).

Step #2: Removing the outer chambers.

Using a 11/16" and a 5/8" wrench or socket, remove the 16 capscrews (item 10), and hex nuts that fasten the outer chambers, diaphragms, and inner chambers together.

Step #3: Removing the diaphragm assemblies.

Use a 1¹/₁₆" (27mm) wrench or six pointed socket to remove the diaphragm assemblies (outer plate, diaphragm, and inner plate) from the diaphragm rod (item 34) by turning counterclockwise.

Insert a 1/4-20 capscrew or set screw into the smaller tapped hole in the inner diaphragm plate (item 28 or 30). Insert the protruding stud and the 1/4-20 fastener loosely into a vise. Use a 1¹/₁₆" wrench or socket to remove the outer diaphragm plate (item 29 or 31) by

turning counter-clockwise. Inspect the diaphragm (item 16) for cuts, punctures, abrasive wear or chemical attack. Replace the diaphragms if necessary.

Step #4: Installing the diaphragms.

Push the threaded stud of the outer diaphragm plate through the center hole of the diaphragm. Thread the inner plate clockwise onto the stud. Insert the loose assembly with the above 1/4-20 fastener back into the vise. Use a torque wrench to tighten the diaphragm assembly together to 480 in. lbs. (54.23 Newton meters). Allow a minimum of 15 minutes to elapse after torquing, then re-torque the assembly to compensate for stress relaxation in the clamped assembly.

Step #5: Installing the diaphragm assemblies to the pump.

Make sure the bumper (item 6) is installed over the diaphragm rod.

Thread the stud of the one diaphragm assembly clockwise into the tapped hole at the end of the diaphragm rod (item 34) until the inner diaphragm plate is flush to the end of the rod. Insert rod into pump.

Align the bolt holes in the diaphragm with the bolt pattern in the inner chamber (item 15).

Fasten the outer chamber (item 14) to the pump, using the capscrews (item 9), and hex nuts.

On the opposite side of the pump, pull the diaphragm rod out as far as possible. Make sure the bumper (item 6) is installed over the diaphragm rod.

Thread the stud of the remaining diaphragm assembly clockwise into the tapped hole at the end of the diaphragm rod (item 34) as far as possible and still allow for alignment of the bolt holes in the diaphragm with the bolt pattern in the inner chamber (item 15).

Fasten the remaining outer chamber (item 14) to the pump, using the capscrews (items 10), hex nuts, and lockwashers.

Step #6: Re-install the manifolds to the pump, using the capscrews (item 10), hex nuts and flat washers.

The pump is now ready to be re-installed, connected and returned to operation.

OVERLAY DIAPHRAGM SERVICING

The overlay diaphragm (item 16) is designed to fit over the exterior of the standard TPE diaphragm (item 18).

One-Piece Bonded DIAPHRAGM SERVICING (Bonded PTFE with integral plate)

The one-piece bonded diaphragm (item 17) has a threaded stud installed in the integral plate at the factory. The inner diaphragm plate has a through hole instead of a threaded hole.

Place the inner plate over the diaphragm stud and thread the first diaphragm / inner plate onto the diaphragms rod only until the inner plate contacts the rod. Do not tighten. A small amount of grease may be applied between the inner plate and the diaphragm to facilitate assembly.

Insert the diaphragm / rod assembly into the pump and install the outer chamber. Turn the pump over and thread the second diaphragm / inner plate onto the diaphragm rod. Turn the diaphragms until the inner plate contacts the rod and hand tighten the assembly. Continue tightening until the bolt holes align with the inner chamber holes. **DO NOT LEAVE THE ASSEMBLY LOOSE.**



! IMPORTANT

Read these instructions completely, before installation and start-up. It is the responsibility of the purchaser to retain this

manual for reference. Failure to comply with the recommendations stated in this manual will damage the pump, and void factory warranty.

Pilot Valve Servicing, Assembly Drawing & Parts List

PILOT VALVE ASSEMBLY PARTS LIST

ITEM	PART NUMBER	DESCRIPTION	QTY
4	095-110-000	Pilot Valve Assembly	1
4-A	095-095-157	Valve Body	1
4-B	755-052-000	Sleeve (With O-rings)	1
4-C	560-033-360	O-ring (Sleeve)	6
4-D	775-055-000	Spool (With O-rings)	1
4-E	560-023-360	O-ring (Spool)	3
4-F	675-037-080	Retaining Ring	1

FOR PUMPS WITH CAST IRON CENTER SECTION

ITEM	PART NUMBER	DESCRIPTION	QTY
4	095-110-558	Pilot Valve Assembly	1
4-A	095-095-558	Valve Body	1

(includes all other items used on 095-110-000)

FOR PUMPS WITH STAINLESS STEEL CENTER SECTION

ITEM	PART NUMBER	DESCRIPTION	QTY
4	095-110-110	Pilot Valve Assembly	1
4-A	095-095-110	Valve Body	1

(includes all other items used on 095-110-000)

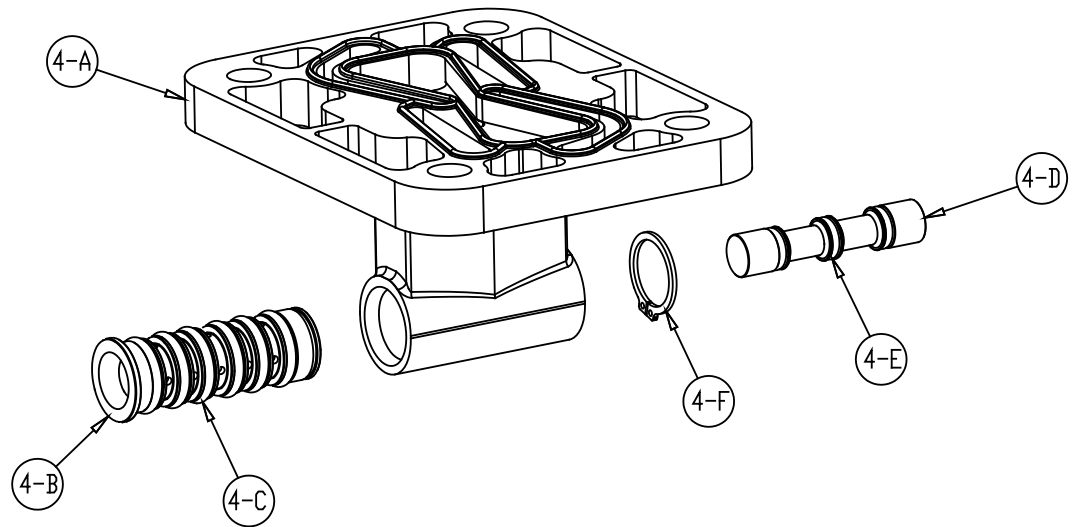

PILOT VALVE SERVICING

To service the pilot valve first shut off the compressed air supply, bleed the pressure from the pump, and disconnect the air supply line from the pump.

STEP #1: See pump assembly drawing.

Using a 1/2" wrench or socket, remove the four capscrews (item 11). Remove the air inlet cap (item 8) and air inlet gasket (item 21). The pilot valve assembly (item 4) can now be removed for inspection and service.

STEP #2: Disassembly of the pilot valve.

Remove the pilot valve spool (item 4-D). Wipe clean and inspect spool and o-rings for dirt, cuts or wear. Replace the o-rings and spool if necessary.

Remove the retaining ring (item 4-F) from the end of the sleeve (item 4-B) and remove the sleeve from the valve body (item 4-A). Wipe clean and inspect sleeve and o-rings for dirt, cuts or wear. Replace the o-rings and sleeve if necessary.

STEP #3: Re-assembly of the pilot valve.

Generously lubricate outside diameter of the sleeve and o-rings. Then carefully insert sleeve into valve body. Take CAUTION when inserting sleeve, not to shear any o-rings. Install retaining ring to sleeve. Generously lubricate outside diameter of spool and o-rings. Then carefully insert spool into sleeve. Take CAUTION when inserting spool, not to shear any o-rings. Use BP-LS-EP-2 multipurpose grease, or equivalent.

STEP #4: Re-install the pilot valve assembly into the intermediate.

Be careful to align the ends of the pilot valve stem between the plunger pins when inserting the pilot valve into the cavity of the intermediate.

Re-install the gasket, air inlet cap and capscrews. Connect the air supply to the pump. The pump is now ready for operation.

ACTUATOR PLUNGER SERVICING

To service the actuator plunger first shut off the compressed air supply, bleed the pressure from the pump, and disconnect the air supply line from the pump.

Step #1: See PUMP ASSEMBLY DRAWING.

Using a 1/2" wrench or socket, remove the four capscrews (items 11). Remove the air inlet cap (item 8) and air inlet gasket (item 21). The pilot valve assembly (item 4) can now be removed.

Step #2: Inspect the actuator plungers.

See ILLUSTRATION AT RIGHT.

The actuator plungers (items 32) can be reached through the pilot valve cavity in the intermediate assembly (item 5).

Remove the plungers (item 32) from the bushings (item 7) in each end of the cavity. Inspect the installed o-ring (items 27) for cuts and/or wear. Replace the o-rings if necessary. Apply a light coating of grease to each o-ring and re-install the plungers in to the bushings. Push the plungers in as far as they will go.

To remove the bushings (item 7), first remove the retaining rings (item 33) by using a flat screwdriver.

NOTE: It is recommended that new retaining rings be installed.

Step #3: Re-install the pilot valve assembly into the intermediate assembly.

Be careful to align the ends of the stem between the plungers when inserting the stem of the pilot valve into the cavity of the intermediate.

Re-install the gasket (item 21), air inlet cap (item 8) and capscrews (item 11).

Connect the air supply to the pump. The pump is now ready for operation.

Actuator Plunger Drawing

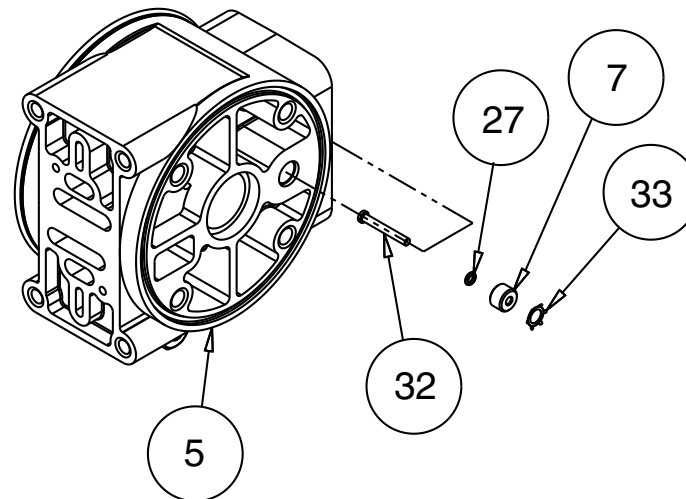

! IMPORTANT

Read these instructions completely, before installation and start-up. It is the responsibility of the purchaser to retain this manual for reference. Failure to comply with the recommendations stated in this manual will damage the pump, and void factory warranty.

CHECK VALVE SERVICING

Before servicing the check valve components, first shut off the suction line and then the discharge line to the pump. Next, shut off the compressed air supply, bleed air pressure from the pump, and disconnect the air supply line from the pump. Drain any remaining fluid from the pump. The pump can now be removed for service.

To access the check valve components, remove the manifold (item 23 or item 24 not shown). Use a 9/16" wrench or socket to remove the fasteners. Once the manifold is removed, the check valve components can be seen.

Inspect the check balls (items 2) for wear, abrasion, or cuts on the spherical surface. The check valve seats (item 36) should be inspected for cuts, abrasive wear, or embedded material on the surfaces of both the external and internal chambers. The spherical surface of the check balls must seat flush to the surface of the check valve seats for the pump to operate to peak efficiency. Replace any worn or damaged parts as necessary.

Re-assemble the check valve components. The seat should fit into the counter bore of the outer chamber.

The pump can now be reassembled, reconnected and returned to operation.

METALLIC SEATS

Two o-rings (or conductive PTFE seals) (item 40) are required for metallic seats.

Check Valve Drawing

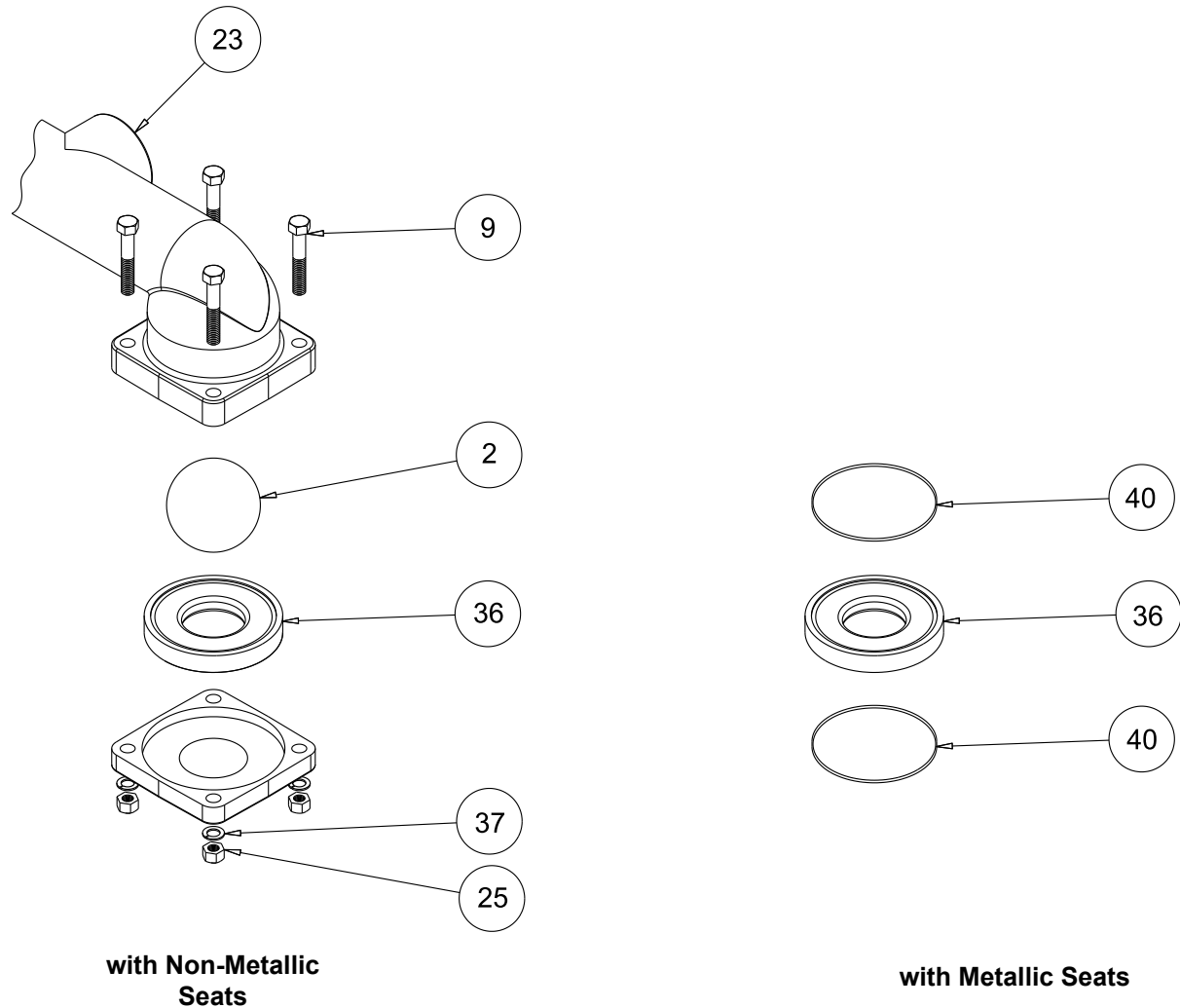

Optional Muffler Configurations, Drawing

OPTION 0 *

530-028-550 Integral Muffler uses (1) Cap and (4) 710-015-115 Self Tapping Screw to hold it in place.

OPTION 1

530-027-000 Sound Dampening Muffler screws directly into the Air Valve body. This muffler is equipped with a porous plastic element.

OPTION 2

530-010-000 Mesh Muffler screws directly into the Air Valve Body. This muffler is equipped with a metal element.



OPTION 6

530-033-000 Metal Muffler screws directly into the Air Body.



ATEX Compliant

* Note: Cannot be used with Air Valve Assembly 031-179-000 used on models equipped with cast iron or stainless steel centers.

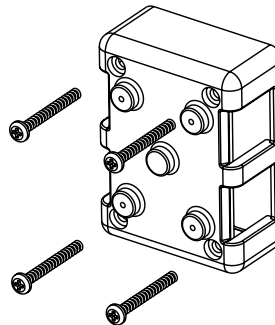
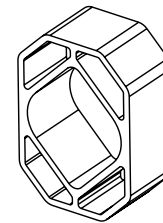
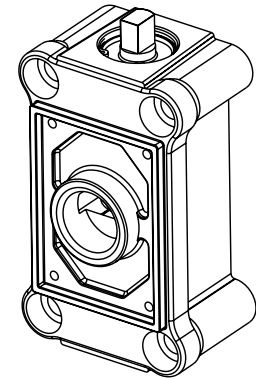

Option 0

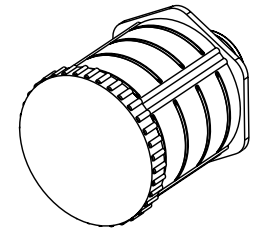

Option 1 and 2

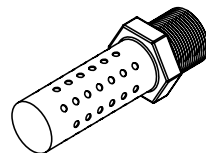

Option 6

PUMPING HAZARDOUS LIQUIDS

When a diaphragm fails, the pumped liquid or fumes enter the air end of the pump. Fumes are exhausted into the surrounding environment. When pumping hazardous or toxic materials, the exhaust air must be piped to an appropriate area for safe disposal. See illustration #1 at right.

This pump can be submerged if the pump materials of construction are compatible with the liquid being pumped. The air exhaust must be piped above the liquid level. See illustration #2 at right. Piping used for the air exhaust must not be smaller than 1" (2.54 cm) diameter. Reducing the pipe size will restrict air flow and reduce pump performance. When the pumped product source is at a higher level than the pump (flooded suction condition), pipe the exhaust higher than the product source to prevent siphoning spills. See illustration #3 at right.

CONVERTING THE PUMP FOR PIPING THE EXHAUST AIR

The following steps are necessary to convert the pump to pipe the exhaust air away from the pump.

Remove the muffler (item 46). The air distribution valve (item 1) has 1" NPT threads for piped exhaust.

IMPORTANT INSTALLATION

NOTE: The manufacturer recommends installing a flexible conductive hose or connection between the pump and any rigid plumbing. This reduces stresses on the molded threads of the air exhaust port. Failure to do so may result in damage to the air distribution valve body.

Any piping or hose connected to the pump's air exhaust port must be conductive and physically supported. Failure to support these connections could also result in damage to the air distribution valve body.

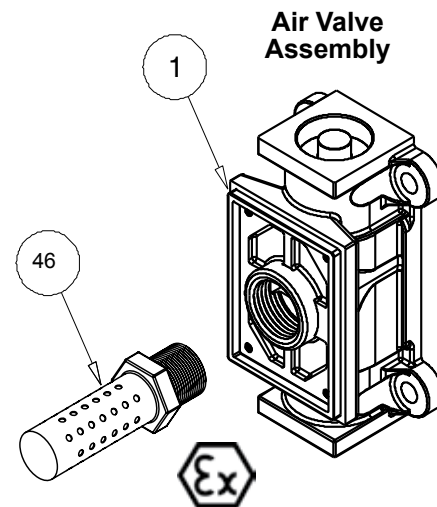

On ATEX compliant units the pump comes equipped with a standard metal muffler

CONVERTED EXHAUST ILLUSTRATION

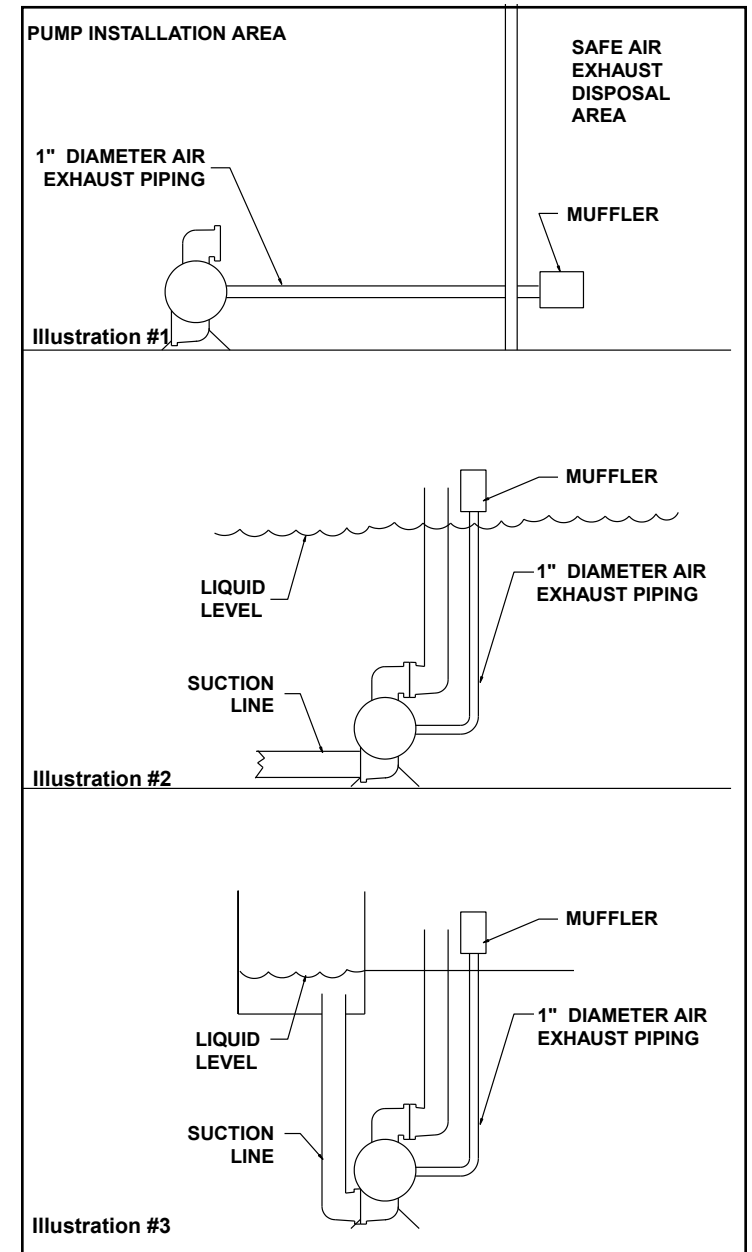

Pulse Output Kit Drawing

PULSE OUTPUT KIT OPTION

This pump can be fitted with a Pulse Output Kit. This converts the mechanical strokes of the pump to an electrical signal which interfaces with the Stroke Counter/ Batch Controller or user control devices such as a PLC.

The Pulse Output Kits mount directly onto the Muffler Cap on the Air Distribution Valve Assembly or onto the air valve and senses each stroke of the main spool.

Consult the factory for further information and availability.

Pulse Output Kits

475-244-001	10-30 VDC
475-244-002	110/220 VAC
475-244-003	10-30VDC, 110VAC and 220 VAC

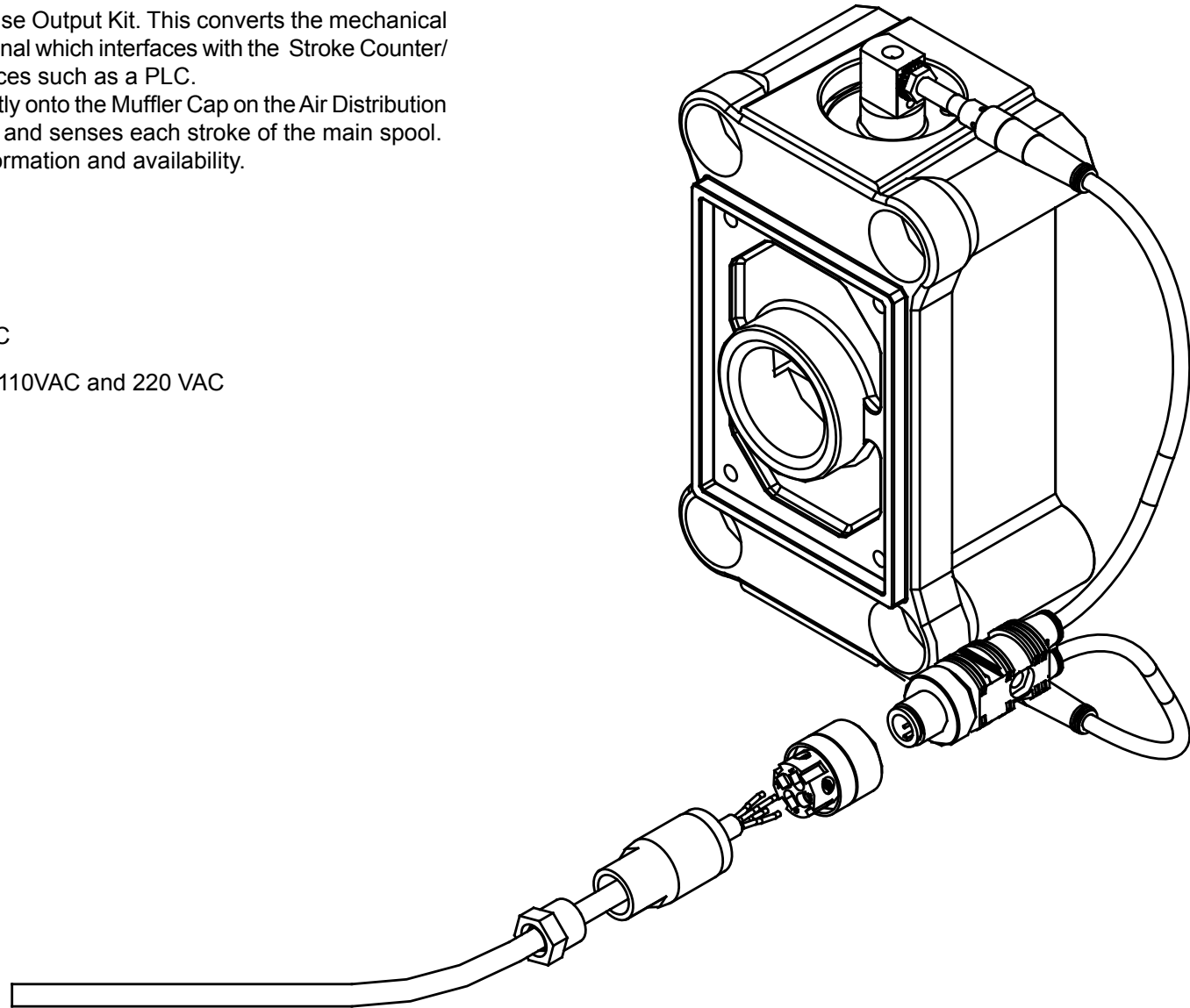

Grounding The Pump

To be fully groundable, the pumps must be ATEX Compliant. Refer to pump data sheet for ordering.

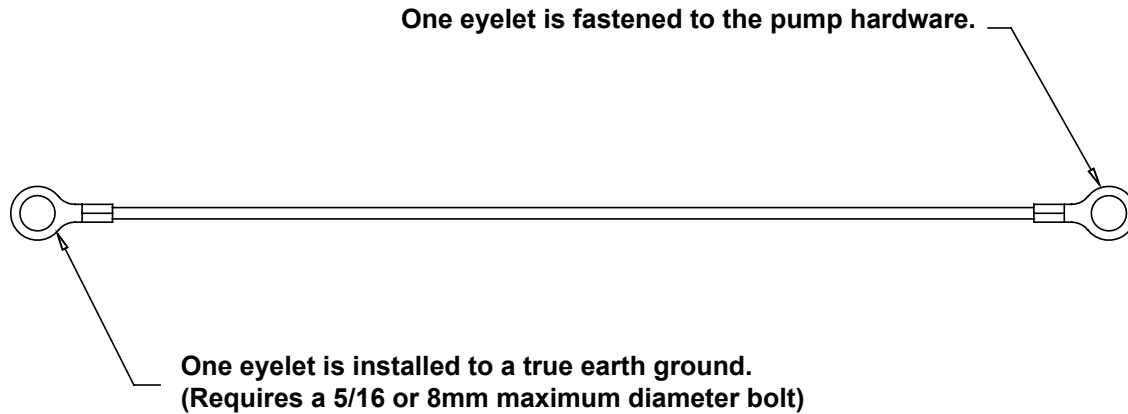

This 8 foot long (244 centimeters) Ground Strap, part number 920-025-000, can be ordered as a service item.

To reduce the risk of static electrical sparking, this pump must be grounded. Check the local electrical code for detailed grounding instruction and the type of equipment required.

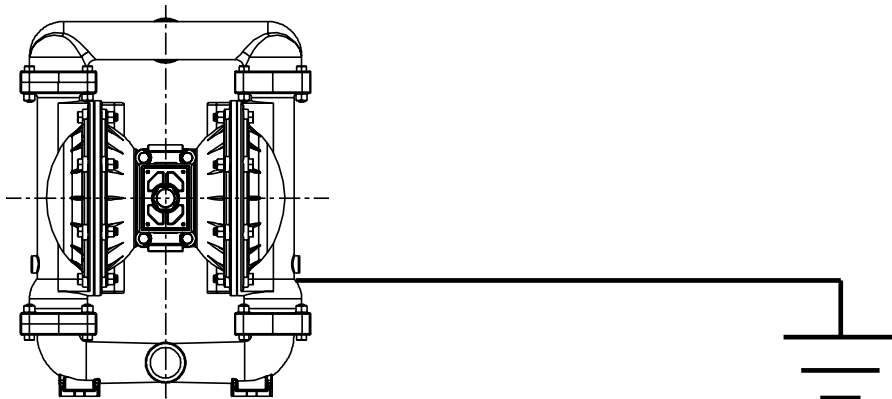

	! WARNING
	<i>Take action to prevent static sparking. Fire or explosion can result, especially when handling flammable liquids. The pump, piping, valves, containers or other miscellaneous equipment must be grounded.</i>



Declaration of Conformity

**Manufacturer: Warren Rupp, Inc.®, 800 N. Main Street, P.O. Box 1568,
Mansfield, Ohio, 44901-1568 USA**

certifies that Air-Operated Double Diaphragm Pump Series:
M Non-Metallic, M Metallic, and Surge Suppressors comply
with the European Community Directive 2006/42/EC on Machinery,
according to Annex VIII. This product has used Harmonized Standard
EN809:1998+A1:2009, Pumps and Pump Units for Liquids - Common Safety
Requirements, to verify conformance.

David Roseberry
Signature of authorized person

October 20, 2005
Date of issue

David Roseberry
Printed name of authorized person

Engineering Manager
Title

Revision Level: F

August 23, 2012
Date of revision



Declaration of Conformity

Declaration of Conformity

Declaration of Conformity

Declaration of Conformity



EC Declaration of Conformity

In accordance with ATEX Directive 94/9/EC,
Equipment intended for use in potentially explosive environments.

Manufacturer: Warren Rupp, Inc.®, A Unit of IDEX Corporation
800 North Main Street, P.O. Box 1568, Mansfield, OH 44901-1568 USA

EN 60079-25: 2011
For pumps equipped with Pulse Output ATEX Option
Quality B.V. (0344)

AODD Pumps and Surge Suppressors
For Type Examination Designations, see page 2 (back)

AODD (Air-Operated Double Diaphragm) Pumps
EC Type Examination Certificate No. Pumps: KEMA 09ATEX0071 X

DEKRA Certification B.V. (0344)
Meander 1051
6825 MJ Arnhem
The Netherlands

Applicable Standard:
EN13463-1: 2009,
EN13463-5: 2011



DATE/APPROVAL/TITLE:
14 MAY 2014

David Roseberry
David Roseberry, Engineering Manager



EC Declaration of Conformity

ATEX Summary of Markings

Type		Marking	Listed In	Non-Conductive Fluids	
Pump types, M05, M1F, M15, M20 and M30 provided with the pulse output option		II 2 G Ex ia c IIC T5 II 3/2 G Ex ia c IIC T5 II 2 D Ex c iaD 20 IP67 T100°C	KEMA 09ATEX0071 X CE 0344	KEMA 09ATEX0071 X KEMA 09ATEX0071 X KEMA 09ATEX0071 X	No Yes Yes
Pump types, M05, M1F, M15 M20 and M30 provided with the integral solenoid option		II 2 G EEx m c II T5 II 3/2 G EEx m c II T5 II 2 D c IP65 T100°C	KEMA 09ATEX0071 X CE 0344	KEMA 09ATEX0071 X KEMA 09ATEX0071 X KEMA 09ATEX0071 X	No Yes Yes
Pump types, MPB1/4, M05, M1F, M15, M20, M30, MSB1, MHDF1, MHDF2 without the above listed options, no aluminum parts		II 1 G c T5 II 3/1 G c T5 II 1 D c T100°C I M1 c I M2 c	KEMA 09ATEX0071 X KEMA 09ATEX0072 X CE 0344	KEMA 09ATEX0071 X KEMA 09ATEX0071 X KEMA 09ATEX0071 X KEMA 09ATEX0071 X KEMA 09ATEX0072 X	No Yes Yes No Yes
Pump types, MPB1/4, M05, M1F, M15, M20, M30, MSB1, MHDF1, MHDF2, MHDF3		II 2 G c T5 II 3/2 G c T5 II 2 D c T100°C	KEMA 09ATEX0072 X CE	KEMA 09ATEX0072 X KEMA 09ATEX0072 X KEMA 09ATEX0072 X	No Yes Yes
MT Series Surge Suppressors		II 2 G T5 II 3/2 G T5 II 2 D T100°C	KEMA 09ATEX0073 CE	KEMA 09ATEX0073 KEMA 09ATEX0073 KEMA 09ATEX0073	No Yes Yes

EC Type Certificate No. Pumps: KEMA 09ATEX0071 X
 Type Certificate No. Pumps: KEMA 09ATEX0072 X
 Type Certificate No. Suppressors: KEMA 09ATEX0073

